



E1200i ExaScale Installation Guide



Force10

Notes, Cautions, and Warnings

-  **NOTE:** A NOTE indicates important information that helps you make better use of your computer.
-  **CAUTION:** A CAUTION indicates potential damage to hardware or loss of data if instructions are not followed.
-  **WARNING:** A WARNING indicates a potential for property damage, personal injury, or death.

Information in this publication is subject to change without notice.

© 2010 Dell Force10. All rights reserved.

Reproduction of these materials in any manner whatsoever without the written permission of Dell Inc. is strictly forbidden.

Trademarks used in this text: Dell™, the DELL logo, Dell Precision™, OptiPlex™, Latitude™, PowerEdge™, PowerVault™, PowerConnect™, OpenManage™, EqualLogic™, KACE™, FlexAddress™ and Vostro™ are trademarks of Dell Inc. Intel®, Pentium®, Xeon®, Core™ and Celeron® are registered trademarks of Intel Corporation in the U.S. and other countries. AMD® is a registered trademark and AMD Opteron™, AMD Phenom™, and AMD Sempron™ are trademarks of Advanced Micro Devices, Inc. Microsoft®, Windows®, Windows Server®, MS-DOS® and Windows Vista® are either trademarks or registered trademarks of Microsoft Corporation in the United States and/or other countries. Red Hat Enterprise Linux® and Enterprise Linux® are registered trademarks of Red Hat, Inc. in the United States and/or other countries. Novell® is a registered trademark and SUSE™ is a trademark of Novell Inc. in the United States and other countries. Oracle® is a registered trademark of Oracle Corporation and/or its affiliates. Citrix®, Xen®, XenServer® and XenMotion® are either registered trademarks or trademarks of Citrix Systems, Inc. in the United States and/or other countries. VMware®, Virtual SMP®, vMotion®, vCenter®, and vSphere® are registered trademarks or trademarks of VMWare, Inc. in the United States or other countries.

Other trademarks and trade names may be used in this publication to refer to either the entities claiming the marks and names or their products. Dell Inc. disclaims any proprietary interest in trademarks and trade names other than its own.

Contents

- 1 About This Guide
 - Information Symbols and Warnings 7
 - Related Publications 8

- 2 The E1200 System
 - Operating Overview 9

- 3 Site Preparation
 - Site Selection Criteria 15
 - Rack Mounting 16
 - Cabinet Placement 16
 - Power 16
 - Fans and Airflow 17
 - Storing Components 17

- 4 Installing the AC Chassis
 - Unpacking the E1200 System. 19
 - Installing the Equipment Rack Shelf Bar. 20
 - Standard Front Chassis Mounting. 20
 - Installing the Chassis into an Equipment Cabinet. 22

- 5 Installing the DC Chassis
 - Unpacking the E1200 System. 23
 - Installing the Equipment Rack Shelf Bar. 24
 - Standard Front Chassis Mounting. 24
 - Installing the Chassis into an Equipment Cabinet. 26

- 6 Installing Fan Trays

- 7 Installing AC Power Supplies
 - Securing the Chassis Ground 30
 - Installing Power Supplies 30
 - AC Power Supply and Fan Operability Test 31

- 8 Installing DC Power Supplies
 - Cable and Connector Requirements 36
 - Installing DC PEMs 36
 - DC Power Supply and Fan Operability Test 40

9	Installing RPMs, Line Cards, and SFM3s	
	Unpacking an RPM or Line Card	43
	Important Points to Remember	43
	Installing Line Cards and RPMs	43
	RPMs	44
	Line Cards	44
	Blank Panels	45
	Preparing and Installing RPMs and Line Cards	45
	Installing a Second RPM	47
	RPM Label and LEDs	47
	Line Card LEDs	48
	Installing Switch Fabric Modules (SFM3s)	48
	SFM3 Front Panel and LEDs	49
	Line Card Cable Management Systems	49
10	RPM Ports and Cables	
	RPM Ports	51
	Connecting the Console and Auxiliary Ports	51
	Cable and Adapter Pin Assignments	52
	Accessing the Console with a DB-9 Adapter	53
	Accessing the Console with a DB-25 Adapter	53
	Accessing the Auxiliary Port by Modem	54
	Accessing the 10/100 Ethernet Management Port	54
	Universal Serial Bus Ports	54
11	Powering Up	
	Preparation	55
	Supplying Power - AC	56
	Supplying Power - DC	56
	Booting to the CLI Prompt	56
	Booting from the BOOT_USER Prompt	57
12	Removing and Replacing Components	
	Removing and Replacing Fan Trays	59
	Removing and Replacing AC Power Supplies	60
	Remove an AC Power Supply in a non-redundant installation	61
	Remove an AC Power Supply in a redundant installation	61
	Removing and Replacing DC Power Supplies	61
	Remove a DC Power Supply	62
	Removing and Replacing RPMs, Line Cards, or SFM3s	63

Removing and Replacing line cards or RPMs	63
Removing and Replacing SFM3s	64
Removing and Replacing the Air Filter	65
13 Using a Flash Memory Card	
External Flash Memory Card	67
Inserting the External Flash Memory Card	67
Removing the External Flash Memory Card	68
Formatting an External Flash Card	68
Copying Files to the External Flash	69
Displaying Files Stored on the External Flash	69
A System Boot	
The System Boot Process	71
System Boot	71
Booting from the BOOT_USER Prompt	71
B Alarms	
Power Supplies Alarms	78
AC Power Supplies and Alarms	78
SFM3s and Alarms	79
C System Specifications	
E1200i AC Chassis Physical Design	81
E1200i AC System Power Requirements	82
E1200i DC Chassis Physical Design	82
E1200i DC System Power Requirements	82
Environmental Specifications	83
Agency Compliance	83
Safety Standards and Compliance Agency Certifications	85
Electromagnetic Emissions	85
Immunity	85
Product Recycling and Disposal	86
D Technical Support	
The iSupport Website	87
Accessing iSupport Services	87
Contacting the Technical Assistance Center	88
Requesting a Hardware Replacement	89

About This Guide

This guide provides site preparation recommendations, step-by-step procedures to rack mount the Force10 Networks E1200 ExaScale chassis, as well as instructions to install its fan trays, power supplies, route processor modules (RPMs), switch fabric modules (SFM3s), and line cards.



The E1200 system is packaged with components necessary for optimal performance, including blank panels for RPM, SFM3, and line card slots. Blanks are required in empty slots to ensure adequate system cooling and for EMI containment during operation.

E1200i systems run Dell Force10 OS (FTOS™) software. After you complete the hardware installation process and power up the system, refer to the *FTOS Configuration Guide* for software configuration information and the *FTOS Command Reference* for detailed CLI information.

Information Symbols and Warnings

Table 1-1 defines the information symbols used throughout this guide.

Table 1-1. Information Symbols

Symbol	Warning	Description
	Note	This symbol informs you of important operational information.
	Caution	This symbol informs you that improper handling and installation could result in equipment damage or loss of data.
	Warning	This symbol signals information about hardware handling that could result in injury.

 **WARNING:** The installation of this equipment shall be performed by trained and qualified personnel only. Read this guide before installing and powering up this equipment. This equipment contains two power cords. Disconnect both power cords before servicing.

 **WARNING:** This equipment contains optical transceivers, which comply with the limits of Class 1 laser radiation.



 **WARNING:** Visible and invisible laser radiation may be emitted from the aperture of the optical transceiver ports when no cable is connected. Avoid exposure to laser radiation and do not stare into open apertures.

 **CAUTION:** Wear grounding wrist straps when handling this equipment to avoid ESD damage.

 **WARNING:** Leakage Current (High Touch Current) in AC-powered systems: AC power cords are secured to the power inlet using the provided brackets. The power cord plugs must be secured to the building outlets by the qualified chassis installer or a qualified electrician.

See [Chapter 3, Site Preparation](#) for more cautions.

Related Publications

For more information about the E1200 system, refer to the following documents:

- FTOS Configuration Guide
- *FTOS Command Reference*
- FTOS Release Notes for the E-Series ExaScale

The E1200 System

The Dell Force10 E1200 system is a carrier-class, high-capacity aggregation router. The 16-slot modular system provides two slots dedicated for Route Processor Modules (RPMs) and 14 slots for line cards with Layer 2 switching and Layer 3 and routing capabilities.

Operating Overview

The E1200 system requires a Route Processor Module (RPM), at least one line card, and at least eight Switch Fabric Modules (SFM3s) for packet processing. The RPM is the core for routing and control operations; all traffic destined for the E1200i terminates on the RPM. Routing table entries are built on the RPM and directed to the forwarding information tables on the line cards.

Software processes, such as Telnet, SNMP, CLI, Layer 2, and Layer 3 functions, are divided among three CPUs for redundancy and speed. Independent software images run on each CPU. Each CPU has its own memory, which isolates processes from each other, increasing reliability. Operating the E1200 system with redundant RPMs enables automatic fail-over redundancy.

Line cards perform all data forwarding operations. Each line card has at least one Force10 Networks proprietary ASIC. The FPC accepts packets, feeds packets to input/output ports, handles packet classification (access lists, and Layer 2 and Layer 3 lookups), and packet-marking (Diffserv or 802.1p). The BTM is responsible for all queuing operations.

The internal flash memory device shipped with the RPM contains the boot ROM and runtime images. Each RPM accommodates an external flash memory card and two USB ports that can be used to copy and store system boot, software images, and configuration files. For information about using a flash card or USB ports, refer to [Chapter 13, Using a Flash Memory Card](#).

Figure 2-1. E1200i AC Chassis Front View

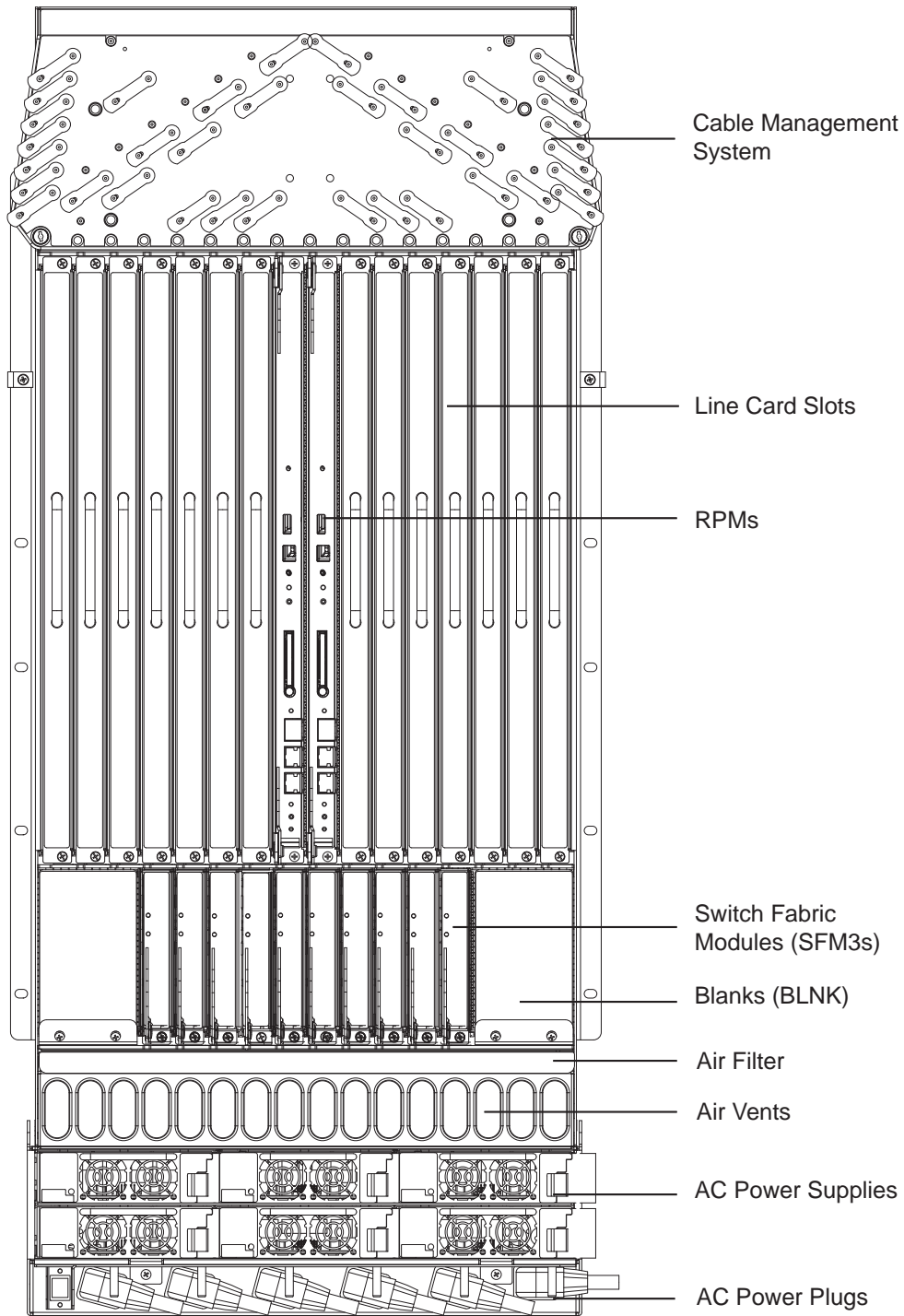

Figure 2-2. E1200 AC Chassis Rear View

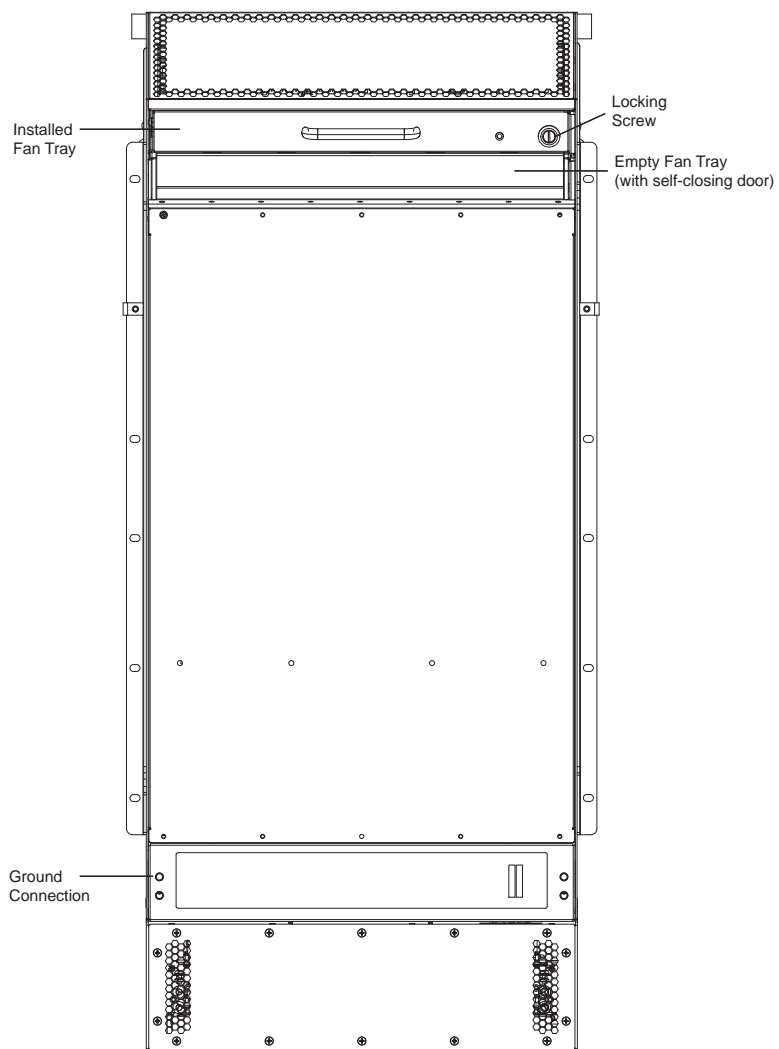

Figure 2-3. E1200i DC Chassis Front View

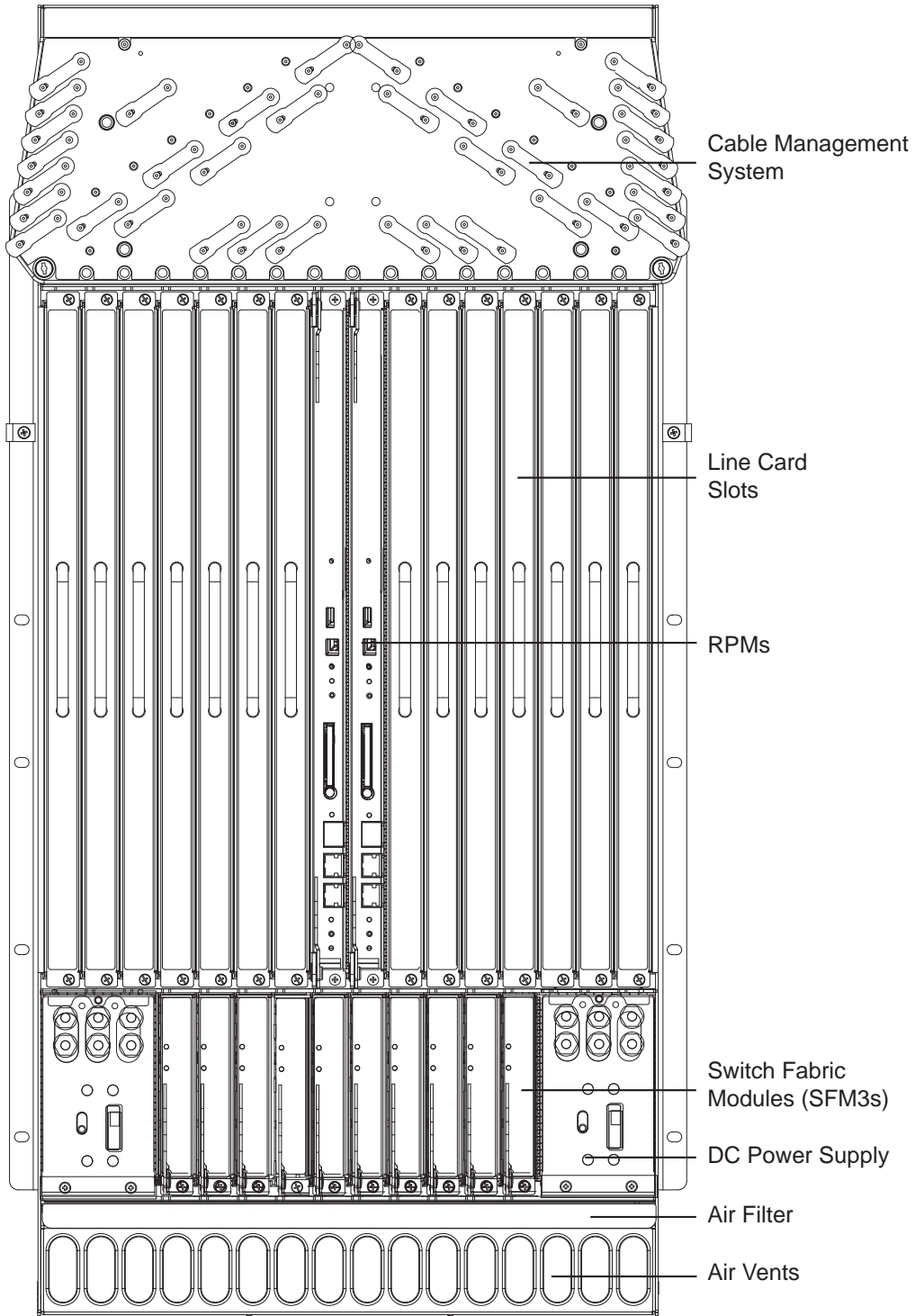

Figure 2-4. E1200 DC Chassis Rear View

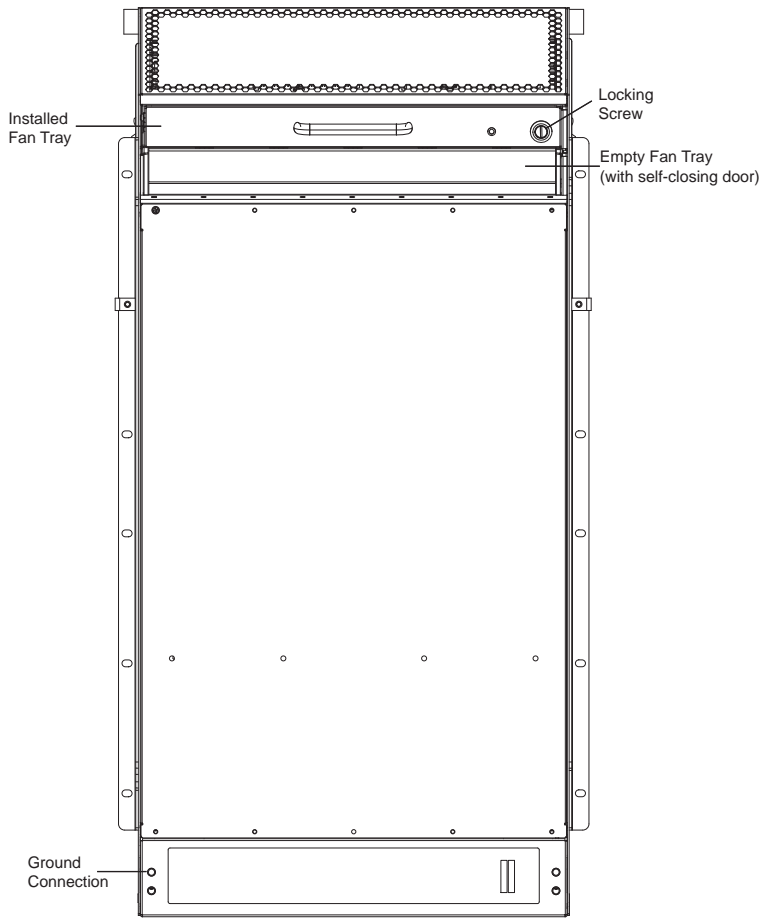

Table 2-1. E1200 Hardware Component Operating Requirements Summary

Component	Minimum	Maximum	Field-Replaceable
Backplane (factory installed)	1	1	N
Air filter (factory installed)	1	1	Y
Fan trays	2	2	Y
RPMs	1	2	Y
Line cards	1	14	Y
SFM3s	8	10	Y
AC Power Supply	3 (in a shelf)	6	Y
DC Power Supply	1	2	Y
Cable management system	0	1	Y
Cable management system cover	0	1	Y

To install the E1200 system:

Step	Task	Section
1	Prepare the site	Site Preparation
2	Unpack the AC chassis and components <i>or</i> Unpack the DC chassis and components	Unpacking the E1200 System Unpacking the E1200 System
3	Mount the AC chassis <i>or</i> Mount the DC chassis	Standard Front Chassis Mounting Installing the Chassis into an Equipment Cabinet Standard Front Chassis Mounting Installing the Chassis into an Equipment Cabinet
4	Install the cable management system	See the instructions that come with the cable management system.
5	Install components: <ul style="list-style-type: none"> • Fan trays • Power Supplies (including power and grounding cables) 	Installing Fan Trays Installing AC Power Supplies Installing DC Power Supplies
6	Verify power supply and fan tray operability	AC Power Supply and Fan Operability Test DC Power Supply and Fan Operability Test
7	Install card components: <ul style="list-style-type: none"> • RPM(s) and line cards • SFM3s 	Installing Line Cards and RPMs Installing Switch Fabric Modules (SFM3s)
8	Connect network cable	RPM Ports and Cables
9	Supply power to the chassis	Supplying Power - AC Supplying Power - DC
10	Initial boot	<p>The initial boot operation automatically brings up the system to the runtime CLI. To interrupt the automatic boot process, issue a break key sequence (Ctrl^) if you experience boot problems.</p> <p>The console monitor will display the default BOOT_USER # prompt. Refer to Chapter A, System Boot for instructions to continue the boot process.</p>

Site Preparation

This chapter describes factors to consider before installing your E1200 system. The following topics are discussed:

- [Site Selection Criteria](#)
- [Rack Mounting](#)
- [Cabinet Placement](#)
- [Power](#)
- [Fans and Airflow](#)
- [Storing Components](#)

For complete E1200 System Specifications, refer to [Chapter C, System Specifications](#).

Site Selection Criteria

Before you begin the installation process, make sure that the area where you intend to install your E1200 meets the following safety requirements.

Select a site:

- In a restricted access area.
- In a dry, clean, well-ventilated and temperature-controlled room, away from nearby heat sources such as hot air vents or direct sunlight.
- Away from sources of severe electromagnetic noise.
- Near an adequate power source. Connect the E1200 to the appropriate branch circuit protection as defined by local electrical codes.
- Means of power disconnect must be located near the equipment.
- Position in a rack with adequate space in the front and rear, and sides of the unit for proper ventilation, access to cables, and maintenance access. Allow *at least* 18 inches in the front and 20 inches in the rear of the rack for ventilation. If placing the chassis in a cabinet, ensure that there is enough clearance between the closed cabinet door and the cables in the cable management system on the chassis.
- Ensure that the ambient temperature around the unit (which may be higher than the room temperature) is within the limit specified for the unit.
- Ensure that there is sufficient airflow around the unit and that the electrical circuits are not overloaded. Consider the nameplate rating of all the connected equipment, and ensure that there is over current protection.

- Ensure that the equipment is properly grounded.
- Do not place objects on top of unit.

△ CAUTION: The E1200 AC shipping containers each weigh up to 400 pounds. The unpacked chassis and pallet weigh approximately 200 pounds. Do not attempt to lift or move the chassis without the use of a hand cart, pallet jack, or forklift. Lift the E1200 chassis *either* from the bottom or by the handles provided with the front shipping cover. Lifting by the chassis shelves or fan tray openings will cause chassis damage. Do not remove the protective front shipping cover until the chassis is secured in the equipment rack.

Rack Mounting

When you prepare your equipment rack, make sure the rack is bolted to the floor and/or braced to a wall or ceiling.

When you install the chassis:

- Make sure that the rack is grounded to the grounding electrode. Each DC PEM must be grounded to the rack or building ground bus. The equipment rack must be grounded to the same grounding electrode used by the power service in your area. The ground path must be permanent.
- Install the E1200 chassis in the rack before you install internal components or make network and power connections.
- In an empty rack, place the chassis in the lower half of the rack to ensure rack stability.

Cabinet Placement

The cabinet must meet the following criteria:

- Minimum cabinet size is 30 inches deep and 24 inches wide.
- Minimum air flow is 750 cubic feet per minute (CFM).
- Minimum of 3 inches between the closed doors and the front of the cable management panel, and a minimum of 3 inches between the chassis rear and the rear of the cabinet with the cabinet door closed. With the rear doors of the cabinet open, you will need a clearance of at least 20 inches from the rear to access the chassis fan trays.
- Minimum of 20 inches clearance at the chassis front to access the air filter, power supplies, and cards.

Power

The E1200 requires 3 AC Power Supplies in a shelf (0, 1, 2 or 3, 4, 5) or 1 DC PEM to operate. For full redundancy, you must have 6 AC Power Supplies (so that if one power supply fails in one shelf, the system remains operational operates with the 3 power supplies in the other shelf) or a second 2 DC Power Entry Module (2 total)

△ CAUTION: You cannot power the system with both types of power supply module installed. The system must contain only one type of power module, either AC or DC.

⚠ WARNING: The E1200i AC Chassis is shipped with two tool-accessible covers preventing access into the alternative DC PEM cavities. Do not remove these covers; they prevent unauthorized access to high direct current locations within the chassis. The covers must remain in place at all times.

⚠ WARNING: Make your chassis ground connections first (see [Figure 2-2](#)). If the chassis is not correctly grounded, excessive electromagnetic emission may result.

⚠ WARNING: Disconnect all power to the equipment rack or cabinet before chassis installation.

⚠ WARNING: Never operate the E1200 system with empty RPM, SFM3, or line card slots. Always replace empty slots with blank panels.

Each E1200 system requires *at least three AC Power Supplies* or *at least one DC Power Supply* to operate. Three AC units are required for power supply redundancy, and so six AC units provides full redundancy. Two DC units are required for power supply and full facility redundancy.

⚠ WARNING: Leakage Current (High Touch Current): The AC power cords are secured to the power inlet using the provided bracket. The AC power cord plugs must be secured to the building outlets by the chassis installer or a qualified electrician.

Refer to [Chapter C, System Specifications](#) for specifications on thermal output and other power related numbers.

Fans and Airflow

Your E1200 chassis contains two field-replaceable fan trays. Air flows through the system from a filtered-intake vent located in the lower part of the chassis. Air circulates from the bottom front (and sides) to the back and exhausts through a top rear vent. The variable fan speed is reduced at normal operating temperatures and increases to full speed as operating temperatures increase, up to 104° F (40° C).

For fan tray access, maintenance and proper ventilation, position the chassis and equipment rack or cabinet so that:

- at least three inches clearance is around the front and side intake and exhaust vents for free air flow
- 20 inches in the rear are available to access the fan tray
- the system can operate with two fan trays.

For instructions on replacing a fan tray, refer to [Removing and Replacing Fan Trays](#).

Storing Components

⚠ CAUTION: Do not transport a chassis with components (line cards, power supplies, RPMs, Fan Trays, Power Supply, or SFM3s) installed in the chassis. Place the modules in their original ESD-preventative packaging and attach the Front Shipping Cover on the front of the chassis prior to placing the chassis in its original shipping crate. Shipping the chassis with components installed may damage the components and the chassis backplane.

If you do not install your E1200 system and components right away, properly store components and all extra field-replaceable components (spares) until you are ready to install them. Keep all components in the original packaging during storage.

Follow these indoor storage guidelines:

- Storage temperature should remain constant ranging from -40° to 158°F (-40° to 70°C).

- Non-condensing relative humidity should be maintained within 5 to 95 percent.
- Store on a dry floor, away from direct sunlight, heat, and air conditioning ducts.
- Store in a dust-free environment.

Installing the AC Chassis

This chapter provides instructions to rack mount your E1200 system into a standard 19-inch or 23-inch equipment rack. It contains the following sections:

- [Unpacking the E1200 System](#)
- [Installing the Equipment Rack Shelf Bar](#)
- [Standard Front Chassis Mounting](#)
- [Installing the Chassis into an Equipment Cabinet](#)

Unpacking the E1200 System

The E1200 AC system and components are shipped on a wooden pallet with a front shipping cover. Remove the chassis from the shipping packaging, and move the chassis with a hand cart, pallet jack, or fork lift to its rack. Do not unpack the power supplies, fan trays, air filter, or cards until the chassis is installed.

 **WARNING:** The E1200 AC shipping containers each weigh up to 400 pounds. The unpacked chassis and pallet weigh approximately 200 pounds. Do not attempt to lift or move the chassis without the use of a hand cart, pallet jack, or forklift.

 **CAUTION:** Lift the E1200 chassis *only* with the handles provided or from the bottom. Lifting by the chassis shelves will cause chassis damage. Do not remove the shipping cover during the installation process. The cover prevents damage to the internal framework and EMI seals.

 **WARNING:** Electrostatic discharge (ESD) damage can occur when components are mishandled. Always wear an ESD-preventative wrist or foot-heel ground strap when handling RPMs, SFM3s, or line cards. After you remove the original packaging, place RPMs, SFM3s, and line cards directly into the chassis, or on an antistatic surface.

 **WARNING:** Complete the chassis installation into the rack before you install any other component (fan trays, power supplies, line cards, RPMs, SFM3s, cables).

To prevent bodily injury when mounting or servicing this unit in a rack, you must take special precautions to ensure that the system remains stable. The following guidelines are provided to ensure your safety:

This unit should be mounted at the bottom of the rack if it is the only unit in the rack.

When mounting this unit in a partially filled rack, load the rack from the bottom to the top with the heaviest component at the bottom of the rack.

If the rack is provided with stabilizing devices, install the stabilizers before mounting or servicing the unit in the rack.

Installing the Equipment Rack Shelf Bar

The rack shelf bar (Figure 4-1) enables you to easily position the chassis into the rack and provides the unit additional stability. The E1200 system must be mounted in a rack that is permanently secured to the floor.

Figure 4-1. Rack Shelf Bar

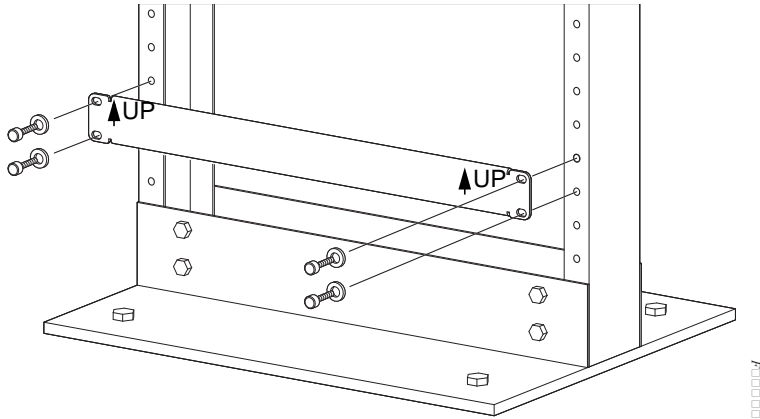

To install a equipment rack shelf bar:

Step	Task
1	Determine the chassis mounting location in the equipment rack.
2	Orient the bar with the arrows pointing upward. The smooth side of the bar should face outward.
3	Attach the bar to the equipment rack brackets using the mounting screws provided by the manufacturer.

Standard Front Chassis Mounting

⚠ WARNING: To prevent bodily injury when mounting or servicing this unit in a rack, you must take special precautions to ensure that the system remains stable. The following guidelines are provided to ensure your safety:

- This unit should be mounted at the bottom of the rack if it is the only unit in the rack.
- When mounting this unit in a partially filled rack, load the rack from the bottom to the top with the heaviest component at the bottom of the rack.
- If the rack is provided with stabilizing devices, install the stabilizers before mounting or servicing the unit in the rack.

⚠ WARNING: Pour éviter toute blessure corporelle pendant les opérations de montage ou de réparation de cette unité en casier, il convient de prendre des précautions spéciales afin de maintenir la stabilité du système. Les directives ci-dessous sont destinées à assurer la protection du personnel:

- Si cette unité constitue la seule unité montée en casier, elle doit être placée dans le bas.
- Si cette unité est montée dans un casier partiellement rempli, charger le casier de bas en haut en plaçant l'élément le plus lourd dans le bas.
- Si le casier est équipé de dispositifs stabilisateurs, installer les stabilisateurs avant de monter ou de réparer l'unité en casier.

⚠ WARNING: Zur Vermeidung von Körperverletzung beim Anbringen oder Warten dieser Einheit in einem Gestell müssen Sie besondere Vorkehrungen treffen, um sicherzustellen, daß das System stabil bleibt. Die folgenden Richtlinien sollen zur Gewährleistung Ihrer Sicherheit dienen:

- Wenn diese Einheit die einzige im Gestell ist, sollte sie unten im Gestell angebracht werden.
- Bei Anbringung dieser Einheit in einem zum Teil gefüllten Gestell ist das Gestell von unten nach oben zu laden, wobei das schwerste Bauteil unten im Gestell anzubringen ist.
- Wird das Gestell mit Stabilisierungszubehör geliefert, sind zuerst die Stabilisatoren zu installieren, bevor Sie die Einheit im Gestell anbringen oder sie warten.

🔧 NOTE: Dell Force10 recommends that you install and operate the E1200 system in a standard 19-inch or 23-inch equipment rack.

Install the E1200 system after you secure the equipment rack shelf bar. Load the chassis in the lower half of an empty rack to avoid a top-heavy rack ([Figure 4-2](#)).

⚠ WARNING: Do not remove the Front shipping Cover during the initial installation process. The cover provides front handles to assist in lifting and prevents damage to the internal framework and EMI seals.

Figure 4-2. Rack Mounting the Chassis

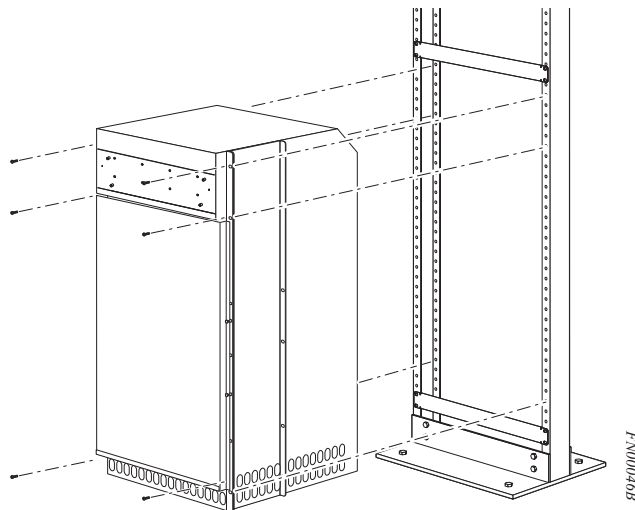

To install the chassis into a prepared rack:

Step	Task
1	If you are center or rear-mounting the chassis in a 19-inch rack, adjust the chassis rack mounting brackets to the desired position.
2	If you are mounting the chassis in a 23-inch rack, install the 23-inch adapter brackets.
3	Using a hand cart, pallet jack, or forklift, align the rack-mount holes with the equipment rack holes, situating the chassis on top of the equipment rack shelf bar.
4	Insert rack mounting screws in the holes that are not obscured by the metal chassis shipping cover. Tighten the screws. See Figure 4-2 .
5	Loosen and remove the screws that secure the chassis Front Shipping Cover and remove the cover.
6	Insert the remaining rack mounting screws and tighten to secure the chassis in the rack.

Installing the Chassis into an Equipment Cabinet

Install the E1200 system after you secure the rack shelf bar. Load the chassis in the lower half of the cabinet to avoid it becoming top-heavy. Make sure the cabinet is positioned with adequate space in the front, rear, and sides of the unit for proper ventilation, access to cables, and access for maintenance.

Refer to [Chapter 3, Site Preparation](#) for complete requirements.

To install the chassis into an equipment cabinet:

Step	Task
1	Install the equipment rack shelf bar.
2	Adjust the chassis mounting brackets to the desired front-rear position and add a 23-inch adapter brackets as required.
3	Using a hand cart, pallet jack, or forklift, align the rack-mount holes with the cabinet holes.
4	Insert rack mounting screws in the holes that are not obscured by the metal chassis shipping cover. Tighten the screws.
5	Loosen and remove the screws attaching the chassis shipping cover. Remove the shipping cover.
6	Insert the remaining mounting screws and tighten to secure the chassis in the cabinet.











Installing the DC Chassis

This chapter provides instructions to rack mount your E1200 system into a standard 19-inch or 23-inch equipment rack. It contains the following sections:

- [Unpacking the E1200 System](#)
- [Standard Front Chassis Mounting](#)
- [Installing the Chassis into an Equipment Cabinet](#)

Unpacking the E1200 System

The E1200 DC system and components are shipped on a wooden pallet with Front Shipping cover. Remove the chassis from the shipping packaging and move the chassis with a hand cart, pallet jack, or fork lift to its rack. Do not unpack the power supplies, fan trays, air filter, or cards until the chassis is installed.

-  **WARNING:** The E1200 DC shipping containers each weigh up to 400 pounds. The unpacked chassis and pallet weigh approximately 200 pounds. Do not attempt to lift or move the chassis without the use of a hand cart, pallet jack, or forklift.
-  **CAUTION:** Lift the E1200 chassis *only* with the handles provided or from the bottom. Lifting by the chassis shelves will cause chassis damage. Do not remove the shipping cover during the installation process. The cover prevents damage to the internal framework and EMI seals.
-  **WARNING:** Electrostatic discharge (ESD) damage can occur when components are mishandled. Always wear an ESD-preventative wrist or foot-heel ground strap when handling RPMs, SFM3s, or line cards. After you remove the original packaging, place RPMs, SFM3s, and line cards directly into the chassis or on an antistatic surface.
-  **WARNING:** Complete the chassis installation into the rack before you install any other component (fan trays, power supplies, line cards, RPMs, SFM3s, cables).
-  **WARNING:** This product relies on the building's installation for short-circuit (overcurrent) protection. Ensure that a fuse or circuit breaker no less than 150A is used on the phase conductors (all current-carrying conductors).
-  **WARNING:** Pour ce qui est de la protection contre les courts-circuits (surtension), ce produit dépend de l'installation électrique du local. Vérifier qu'un fusible ou qu'un disjoncteur de 150A? est utilisé sur les conducteurs de phase (conducteurs de charge).
-  **WARNING:** Dieses Produkt ist darauf angewiesen, daß im Gebäude ein Kurzschluß- bzw. Überstromschutz installiert ist. Stellen Sie sicher, daß eine Sicherung oder ein Unterbrecher von nicht mehr 150A? an den Phasenleitern (allen stromführenden Leitern) verwendet wird.
-  **WARNING:** Class 1 laser product.
-  **WARNING:** Produit laser de classe 1.
-  **WARNING:** Laserprodukt der Klasse 1.

Installing the Equipment Rack Shelf Bar

The rack shelf bar (Figure 5-1) enables you to easily position the chassis into the rack and provides the unit additional stability. The E1200 system must be mounted in a rack that is permanently secured to the floor.

Figure 5-1. Rack Shelf Bar

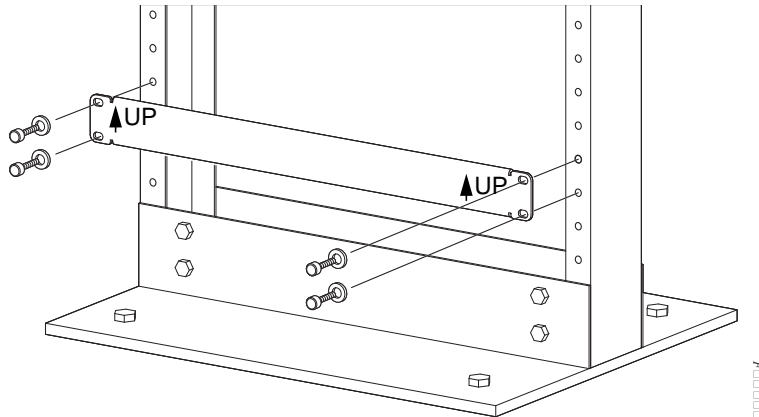

To install a equipment rack shelf bar:

Step	Task
1	Determine the chassis mounting location in the equipment rack.
2	Orient the bar with the arrows pointing upward. The smooth side of the bar should face outward.
3	Attach the bar to the equipment rack brackets using the mounting screws provided by the manufacturer.

Standard Front Chassis Mounting

⚠ WARNING: To prevent bodily injury when mounting or servicing this unit in a rack, you must take special precautions to ensure that the system remains stable. The following guidelines are provided to ensure your safety:

- This unit should be mounted at the bottom of the rack if it is the only unit in the rack.
- When mounting this unit in a partially filled rack, load the rack from the bottom to the top with the heaviest component at the bottom of the rack.
- If the rack is provided with stabilizing devices, install the stabilizers before mounting or servicing the unit in the rack.

⚠ WARNING: Pour éviter toute blessure corporelle pendant les opérations de montage ou de réparation de cette unité en casier, il convient de prendre des précautions spéciales afin de maintenir la stabilité du système. Les directives ci-dessous sont destinées à assurer la protection du personnel:

- Si cette unité constitue la seule unité montée en casier, elle doit être placée dans le bas.
- Si cette unité est montée dans un casier partiellement rempli, charger le casier de bas en haut en plaçant l'élément le plus lourd dans le bas.
- Si le casier est équipé de dispositifs stabilisateurs, installer les stabilisateurs avant de monter ou de réparer l'unité en casier.

⚠ WARNING: Zur Vermeidung von Körperverletzung beim Anbringen oder Warten dieser Einheit in einem Gestell müssen Sie besondere Vorkehrungen treffen, um sicherzustellen, daß das System stabil bleibt. Die folgenden Richtlinien sollen zur Gewährleistung Ihrer Sicherheit dienen:

- Wenn diese Einheit die einzige im Gestell ist, sollte sie unten im Gestell angebracht werden.
- Bei Anbringung dieser Einheit in einem zum Teil gefüllten Gestell ist das Gestell von unten nach oben zu laden, wobei das schwerste Bauteil unten im Gestell anzubringen ist.
- Wird das Gestell mit Stabilisierungszubehör geliefert, sind zuerst die Stabilisatoren zu installieren, bevor Sie die Einheit im Gestell anbringen oder sie warten.

📝 NOTE: Dell Force10 recommends that you install and operate the E1200 system in a standard 19-inch or 23-inch equipment rack.

Install the E1200 system after you secure the equipment rack shelf bar. Load the chassis in the lower half of an empty rack to avoid a top-heavy rack ([Figure 5-2](#))

⚠ WARNING: Do not remove the Front shipping Cover during the initial installation process. The cover provides front handles to assist in lifting and prevents damage to the internal framework and EMI seals.

Figure 5-2. Rack-Mounting the Chassis

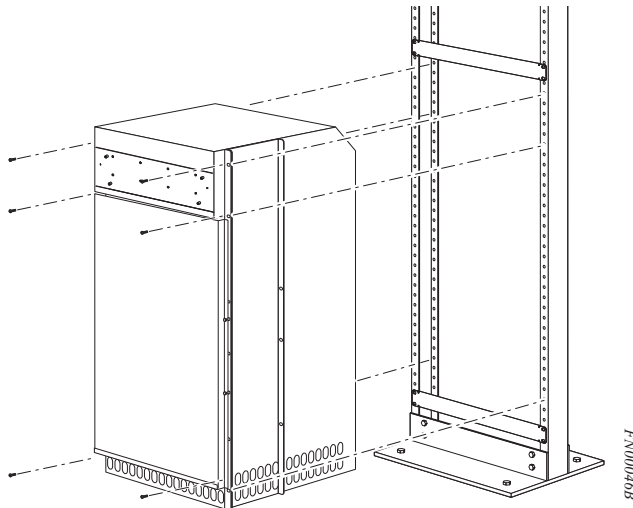

To install the chassis into a prepared rack:

Step	Task
1	If you center- or rear-mount the chassis in a 19-inch rack, adjust the chassis rack-mounting brackets to the desired position.
2	If you mount the chassis in a 23-inch rack, install the 23-inch adapter brackets.
3	Use a hand cart, pallet jack, or forklift to align the rack-mount holes with the equipment rack holes, situating the chassis on top of the equipment rack shelf bar.
4	Insert rack-mounting screws in the holes that are not obscured by the metal chassis shipping cover. Tighten the screws. See Figure 5-2 .
5	Loosen and remove the screws that secure the chassis Front Shipping Cover and remove the cover.
6	Insert the remaining rack-mounting screws and tighten to secure the chassis in the rack.

Installing the Chassis into an Equipment Cabinet

Install the E1200 system after you secure the rack shelf bar. Load the chassis in the lower half of the cabinet to avoid it becoming top-heavy. Make sure the cabinet is positioned with adequate space in the front, rear, and sides of the unit for proper ventilation, access to cables, and access for maintenance.

Refer to [Chapter 3, Site Preparation](#) for complete requirements.

To install the chassis into an equipment cabinet:

Step	Task
1	Install the equipment rack shelf bar.
2	Adjust the chassis mounting brackets to the desired front-rear position and add a 23-inch adapter brackets as required.
3	Using a hand cart, pallet jack, or forklift, align the rack-mount holes with the cabinet holes.
4	Insert rack-mounting screws in the holes that are not obscured by the metal chassis shipping cover. Tighten the screws.
5	Loosen and remove the screws attaching the chassis shipping cover. Remove the shipping cover.
6	Insert the remaining mounting screws and tighten to secure the chassis in the cabinet.

Installing Fan Trays

Access the fan tray slots from the rear of the chassis (Figure 6-1). Two fan trays are required in the chassis. When a fan tray is not installed in the lower slot, a self-closing door will seal the slot. Panel blanks are not required. However, to ensure fail-safe chassis operation, do not operate the chassis with only one fan tray for more than 30 minutes.

⚠ WARNING: Install the fan trays before you supply power to the system.

⚠ WARNING: Electrostatic discharge (ESD) damage can occur when components are mishandled. Always wear an ESD-preventative wrist or foot-heel ground strap when handling chassis components. After you remove the original packaging, place chassis components on an antistatic surface.

Figure 6-1. Installing Fan Tray

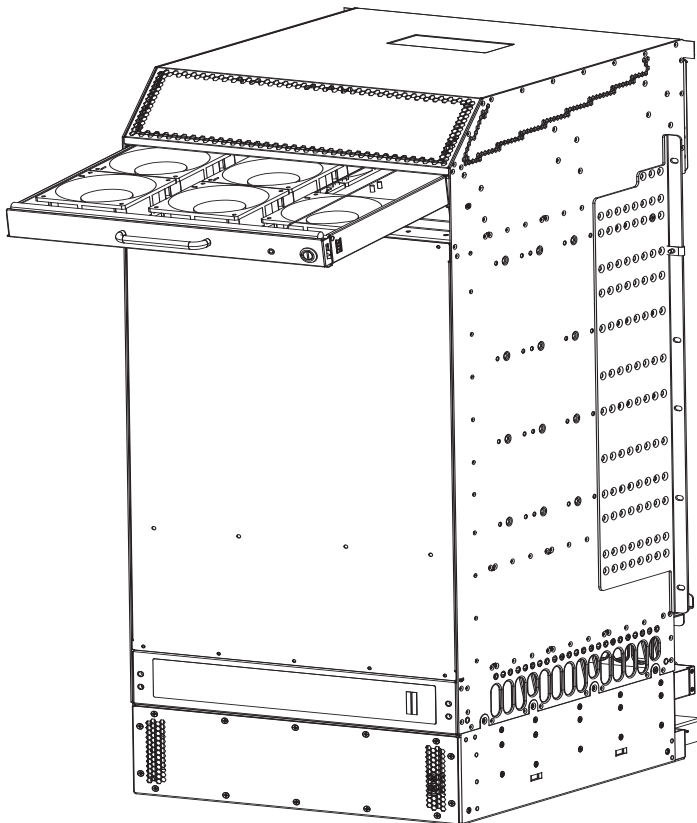
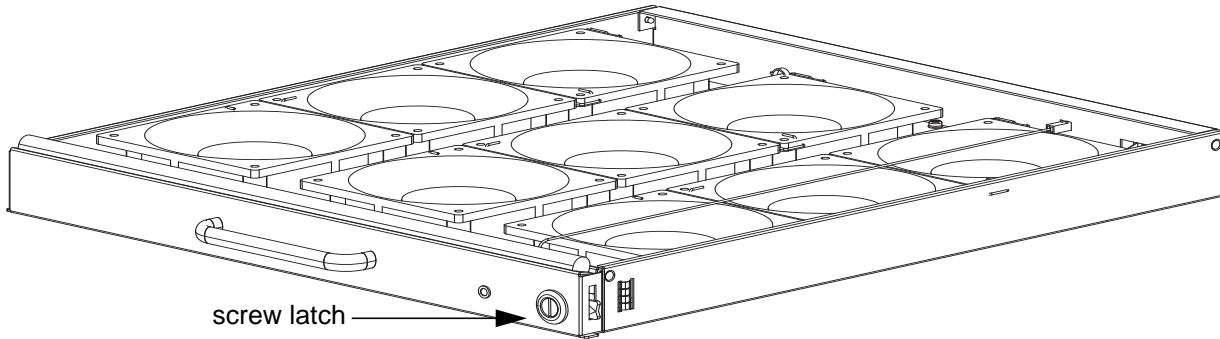

Figure 6-2. Fan Tray

Install the fan trays after the chassis is installed securely in the equipment rack. Access the fan tray slots from the rear side of the chassis. To ensure proper temperature and airflow control, all six fan trays must be installed before you supply power to the system. You will need a #2 Phillips screwdriver to tighten the screws that secure the fan trays to the chassis. A fan tray can be installed in any fan tray slot.

To install fan trays:

⚠ WARNING: Table 6-1 is an illustration of the fan tray safety labels: Prevent exposure and contact with hazardous voltages. Do not attempt to operate this system without the safety cover provided with each PEM.

Step	Task
1	Unpack the fan tray.
2	Prior to inserting a fan tray, fully turn its screw latch counter-clockwise (with flathead screwdriver) until the fan tray latching mechanism fully retracts into the fan tray (see Figure 6-2).
3	Grip the fan tray handle. Slide the connector end of each fan tray into the slot until it stops and the handle end is flush with the chassis rear.
4	Secure the fan trays into place by turning the screw latch clockwise.

Table 6-1. Fan Tray Safety Labels

Label	Location
 CAUTION Verify fan blades have stopped rotating before removing fan tray	Fan tray faceplate

Installing AC Power Supplies

The E1200 system requires a minimum of 3 AC power supplies in a shelf (0, 1, 2 or 3, 4, 5) to operate. For full redundancy use 6 power supplies so that if one power supply fails in one shelf, the system remains operational operates with the 3 power supplies in the other shelf. To comply with safety agency and EMI regulations, you *must* install the AC-cord retainer over all power cords. The E1200 chassis contains 6 AC power supply slots, as shown in [Figure 7-1](#).

- NOTE:** If you are installing only three power supplies, they must be installed in the same row. FTOS will generate an error message if the three power supplies are not in the same row.
- NOTE:** The On/Standby switch disconnects power to the rest of the chassis from *all* 6 AC power supplies slots. When the AC cord is attached, power supply fans will spin and the LEDs will indicate status while the On/Standby switch is in Standby.

Figure 7-1. E1200i AC Power Supply Shelf

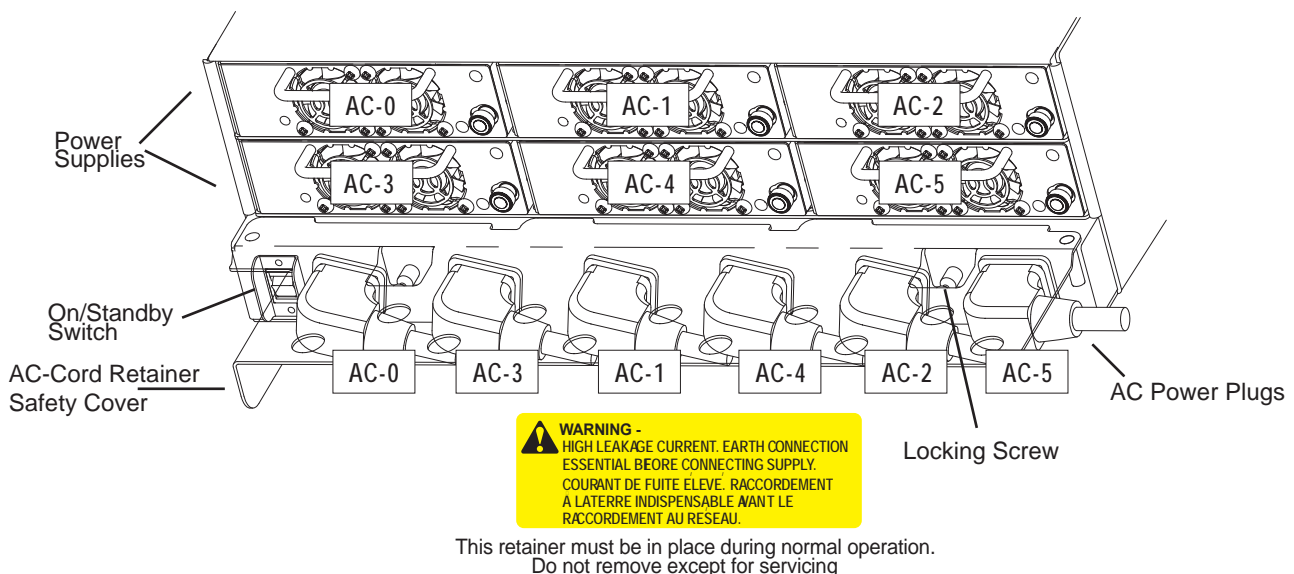

Securing the Chassis Ground

Step	Task
1	Locate the chassis ground connector nuts on the chassis rear (see Figure 2-2).
2	Install the grounding cables to the ground nuts. The grounding cable must comply with your local electrical codes in size and color (typically the color is green or green with yellow stripe). <p>NOTE: Grounding cables must be terminated only with a UL-listed 2-hole lug with 1/4-inch holes on 3/4-inch spacing (see Figure 7-2).</p> <p>Use ANSI UNC 1/4-20 x 1/2 bolt.</p> <p>Tighten the bolt (torque should not exceed 25inch/lbs).</p> <p>Connect the opposite end of the grounding cable to the nearest appropriate facility grounding post.</p>

Figure 7-2. Cable Connector Required for E1200i AC

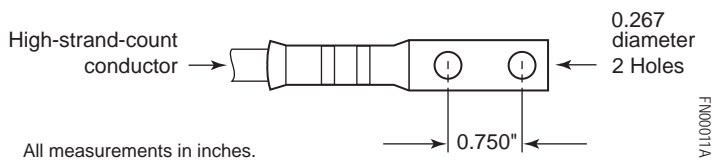

Installing Power Supplies

CAUTION: An E1200i AC power supply still has power after extraction, and has completely powered off when the fans have stopped rotating. When replacing a power supply, to avoid arcing and discoloration of the supply and the chassis pins, please wait for the fans to stop rotating before reinserting the supply.

Power Cord Requirements

If using a power cord other than a Dell Force10 supplied power cord, the cord must terminate at a right angle to the power module, see [Figure 7-1](#). The power source end of the power cord must have an appropriately sized plug that complies with your local electrical codes. Conductor size must also conform to your local electrical codes.

CAUTION: Ensure that the socket-outlet is located/installed near the equipment and is easily accessible. Disconnect the power cord before servicing a power module.

WARNING: This unit has more than one power supply connection; all connections must be removed to remove all power from the unit.

WARNING: Cette unité est équipée de plusieurs raccords d'alimentation. Pour supprimer tout courant électrique de l'unité, tous les cordons d'alimentation doivent être débranchés.

WARNING: Diese Einheit verfügt über mehr als einen Stromanschluß; um Strom gänzlich von der Einheit fernzuhalten, müssen alle Stromzufuhren abgetrennt sein.

The following are Dell Force10 supplied plug types. All power plugs must comply with local codes. Check with your Dell Force10 representative to purchase cords or plugs for your system.

- EU: CEE 7/7
- UK: CEE7/7
- SWZ: CEE7/7, 309

- JAP: NEMA 6-20, L6-20, L6-30
- JAP 220: NEMA 6-20, L6-20
- US: C20
- US 220: NEMA 6-20, L6-20, L6-30 (30A)

CAUTION: The power cord is the main power disconnect device; ensure that the socket-outlet is located/ installed near the equipment and is easily accessible.

Step	Task
1	Make sure that the On/Standby switch, located on the left side of plug AC-0, is in the Standby (up) position (Figure 7-1).
2	Loosen the cord retainers locking screws (if needed) and tilt the AC-cord retainer up approximately 15° and gently slide the cover away from the chassis.
3	Slide the power supplies into their slots until the module front is flush with the shelf front.

Figure 7-3. Insert power supply

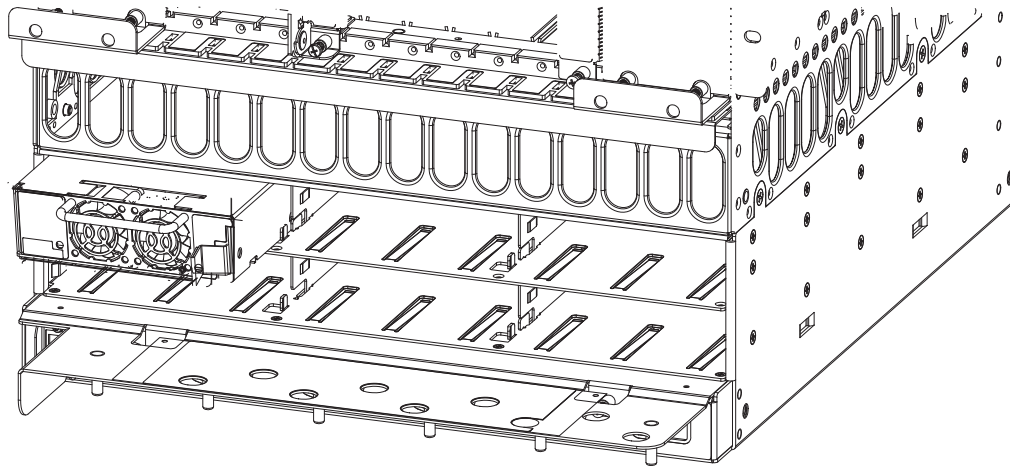

- 4 Connect the Power Supply cord to the designated socket (Figure 7-1).
- 5 Re-install the AC-cord Retainer by tilting approximately 15° and gently sliding in the long edge just above the AC cords.
- 6 Secure the retainer by tighten the locking screws on either side of the retainer.

WARNING: Leakage Current (High Touch Current) in AC-powered systems: AC power cords are secured to the power inlet using the provided brackets. The power cord plugs must be secured to the building outlets by the qualified chassis installer or a qualified electrician.

AC Power Supply and Fan Operability Test

Once your power supplies and fan trays are installed, verify their operability by supplying power to the chassis and verifying the status LEDs.

Before you begin this power test, inspect your equipment rack and chassis. Verify that:

- Each Power Supply is properly installed and plugged into the assigned slot.

- The AC-cord Retainer is secured over the plugs.

⚠ WARNING: Prevent exposure and contact with hazardous voltages. Do not attempt to operate this system without the AC-cord Retainer.

- Your power cables connect to an appropriate AC power supply in a manner that complies with your local electrical codes. For AC systems, a Main Disconnect must be provided for each AC cord.
- Two fan trays are installed.

To test the power supplies and fan trays:

Step	Task
1	With the fan trays and power supplies installed, power on the system. <ul style="list-style-type: none"> • Flip the On/Standby switch located next to plug AC-0 to the ON position (up).
2	Power Supply Status LEDs should be green. The LED is unlit when the system is off or blinking green when the system is booting. During boot, the blinking green LED may switch to blinking amber until the RPM boot is complete. <ul style="list-style-type: none"> • Check that the units are properly installed and are plugged into the correct slot. • Verify the power source. • If the LED remains unlit or is blinking amber after the system has booted, replace the power supply.
3	Both fan tray LEDs should be green (online). blinking green fan tray LED indicates that the system is booting. During boot, the blinking green LED may switch to blinking amber until the RPM boot is complete. If a fan tray is not operating properly or air is not flowing through the chassis: <ul style="list-style-type: none"> • Power off the chassis at the remote power source. • Ensure that all fan trays are properly installed. • Verify the remote power source. • If a fan tray LED is unlit or is blinking amber after the system has booted, replace the fan tray.
4	After you have verified the power and fan operability, power off the chassis to continue the installation process.
5	De-energize the Main Disconnect and flip the On-Off switch to the OFF position.
6	Verify that the LEDs are not lit.

Power Supply and Fan Tray LEDs

Table 7-1. Power Supply LEDs

Status	LED is ...
No AC power	Unlit: No connection
Operational (On/Standby switch may be set to Standby)	Lit: GREEN
Power Supply Failure	Lit: AMBER

Table 7-2. Fan Tray LEDs

Status	LED is ...
Booting	Blinking: GREEN
Fault Detected	Lit: YELLOW
Communication Failure	Blinking: YELLOW
Operational	Lit: GREEN
Loss of Power	Unlit

Installing DC Power Supplies

The E1200 system requires a minimum of one DC Power Entry Module (PEM) to operate, but 2 are recommended for redundancy. To comply with safety agency and EMI regulations, you *must* install covers on all power supply slots not containing a PEM. Connect the PEMs to the appropriate branch circuit protection as defined by local electrical codes.

For full redundancy, each PEM must be attached to an independent power source with a dedicated circuit breaker. For example, the PEM in slot 0 connects to circuit breaker A and the PEM in slot 1 connects to circuit breaker B.

The E1200 chassis contains two DC PEM slots, as shown in [Figure 8-1](#).

Figure 8-1. PEM 0 and PEM 1 Chassis Locations

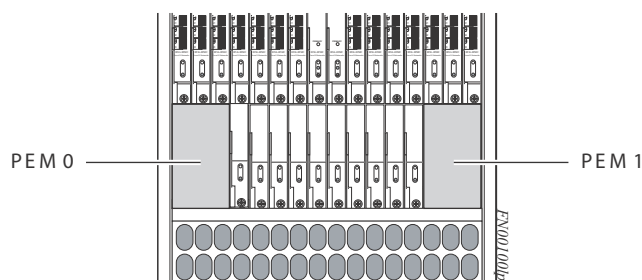

The DC PEM shown in [Figure 8-2](#) is used in both the E1200 and E1200i DC chassis.

Figure 8-2. E1200i DC PEM

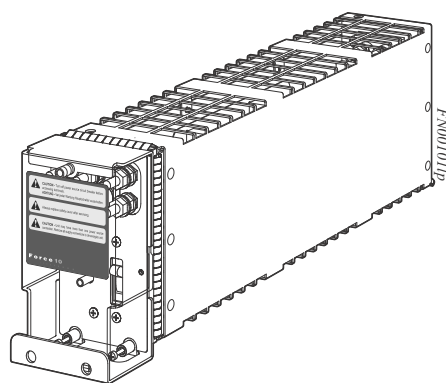
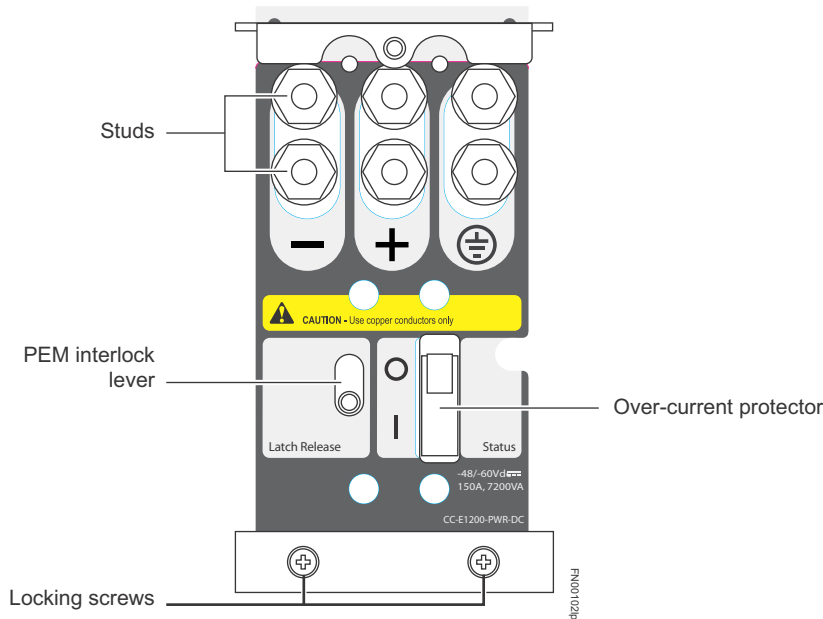

Figure 8-3. E1200 PEM Front Panel

Cable and Connector Requirements

You must provide your own cables to connect to a remote power source (for example, a circuit breaker panel) in your equipment rack or office. Cables must be sized to meet the following criteria:

- rated for at least 150A service to allow for a fully loaded E1200 system at low input voltage per your local electrical codes
- limits voltage drop across the cable length to 0.5V or less

Before you make the cable connections, apply a coat of antioxidant paste to un-plated metal contact surfaces. File un-plated connectors, braided straps, and bus bars to a shiny finish. It is not necessary to file and coat tinned connectors or other plated connection surfaces, such as on the E1200 PEM studs.

Installing DC PEMs

- △ **CAUTION:** Provide an easily accessible external disconnect. Dell Force10 recommends that you use a 150A circuit breaker.
- △ **CAUTION:** Un interrupteur externe doit être fournis et doit être facilement accessible. Dell Force10 recommande l'utilisation d'un disjoncteur de 150Ampères. Eine leicht zugängliche Trennvorrichtung muss in der.
- △ **CAUTION:** Verdrahtung eingebaut sein. Dell Force10 empfiehlt, dass Sie einen 150A Sicherungsautomaten benutzen.

Each E1200 system requires *at least one* load-sharing DC PEM to operate. Two units are recommended for full facility redundancy.

Parameter	Specifications
Maximum DC PEM Input Current	150A
Maximum Power Dissipation	6850W (21,598 BTU/hour)

Parameter	Specifications
Input Voltage	-48 to -60 Vdc

Use the following steps to install a DC PEM:

Step	Task
1	Make sure that the remote power source (the circuit breaker panel) is in the OFF position.
2	Make sure that the over-current protector (located on the PEM front panel) is in the OFF position.
3	Loosen the retaining screw and remove the PEM safety cover.

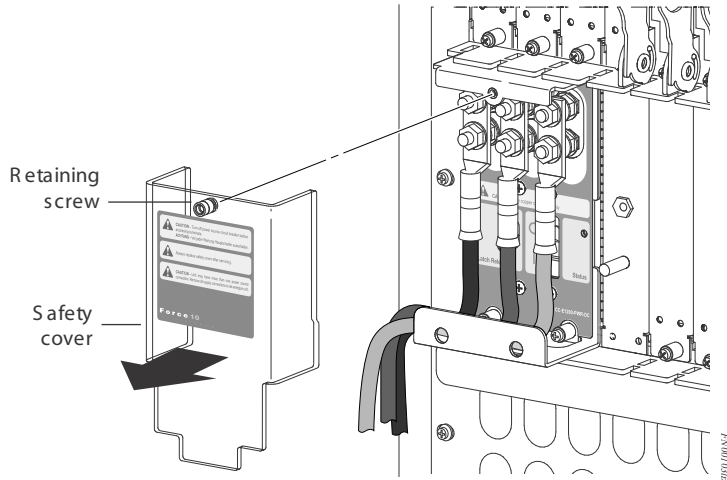

- 4 Slide the PEM into the 0 or 1 slot (Figure b):
 - a Lift up and hold the PEM interlock lever and carefully push the unit inward to fully seat it to the backplane. When the PEM is fully inserted, the interlock lever will drop to hold the PEM in position.
 - b Tighten the two locking screws with a #2 Phillips screw driver to secure the PEM. Do not exceed 5 inch/lbs torque.

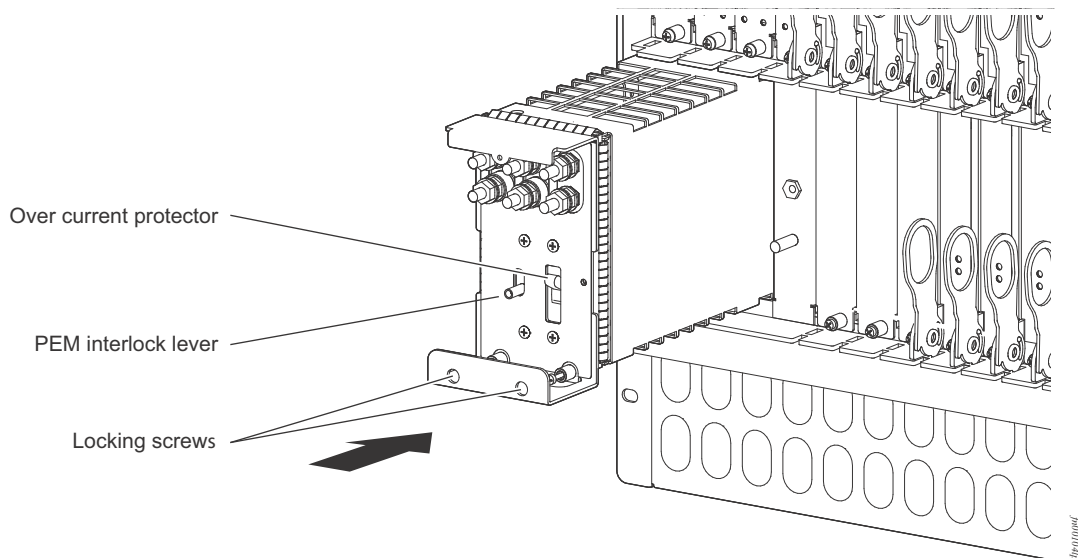

Step	Task (continued)
5	<p>Secure the chassis ground connection first:</p> <ul style="list-style-type: none"> a Remove one outer nut and one washer from each of the six studs. One nut should remain, tighten on the stud to 20 in/lbs. If the inner nut is loose, re-tighten it to 25 in/lbs. b Locate the chassis ground connector studs on the PEM front panel (see Figure 8-3). The two rightmost studs are the ground connection. c Install the grounding cable onto the ground studs. The grounding cable must comply with your local electrical codes in size and color (typically the color is green or green with yellow stripe). <p>NOTE: Grounding cables must be terminated only with a UL-listed 2-hole lug with 1/4-inch holes on 3/4-inch spacing (see Figure 8-4).</p> <ul style="list-style-type: none"> d Replace the two washers and nuts on the studs. e With a 7/16-inch box or socket wrench, tighten the nuts (torque should not exceed 25 inch/lbs). f Connect the opposite end of the grounding cable to the nearest appropriate facility grounding post.

Figure 8-4. Cable Connector Required for E1200 PEM

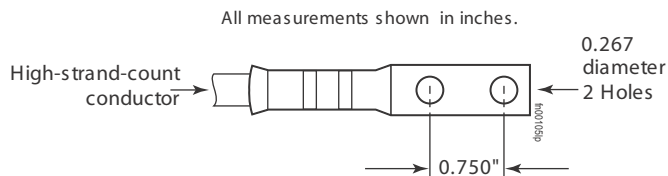

- 6 Connect the -48 VDC and Return cables from each PEM to the remote power sources (circuit breakers A and B).
- a Check that the remote power sources (for example, circuit breakers) are in the **OFF** position.
 - b Locate the appropriate studs on the PEM front panel ([Figure 8-3](#)).
 - c The two leftmost studs on the PEM are the -48 VDC (-) connection. **The cable attached to these studs is typically black.**
 - The two middle studs are the return (+) connection. **The cable attached to these studs is typically red.**
 - d Install the -48 VDC and Return cables on the studs. The cables should be of the size and color to comply with local electrical codes.
- NOTE:** Power cables must be terminated only with a UL-listed 2-hole lug with 1/4-inch studs with 3/4-inch spacing ([Figure 8-6](#)).
- e Replace the washers and nuts on the studs.
 - f With a 7/16-inch box or socket wrench, tighten the nuts.

Step Task (continued)

7 Route the terminated cables down and toward the rack rail, as shown below.

Figure 8-5. Connecting the Ground Cable to the E1200 PEM

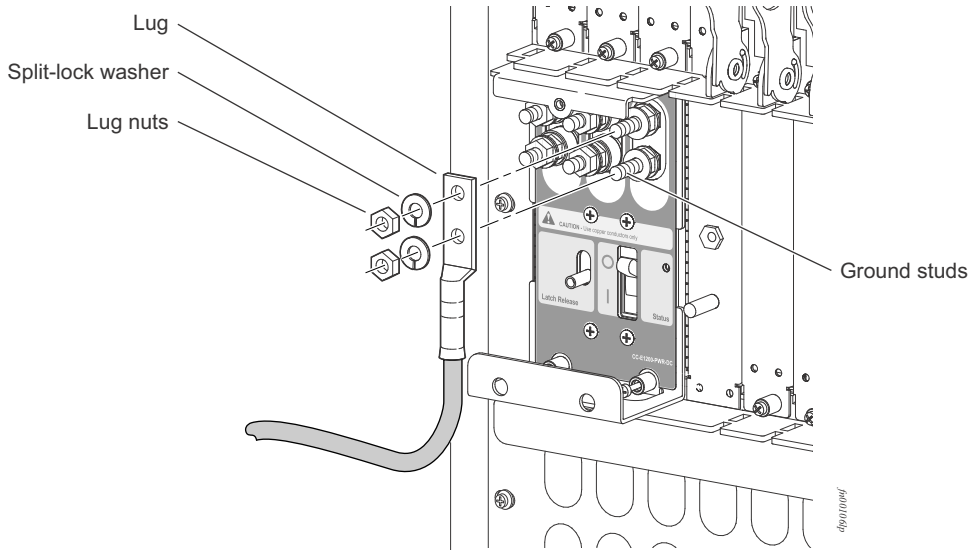
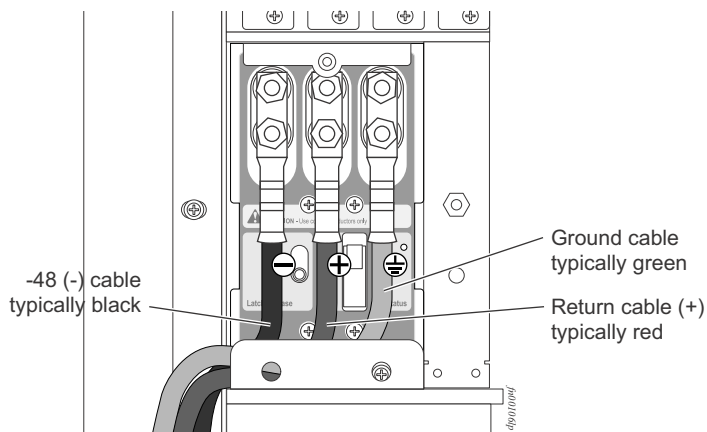
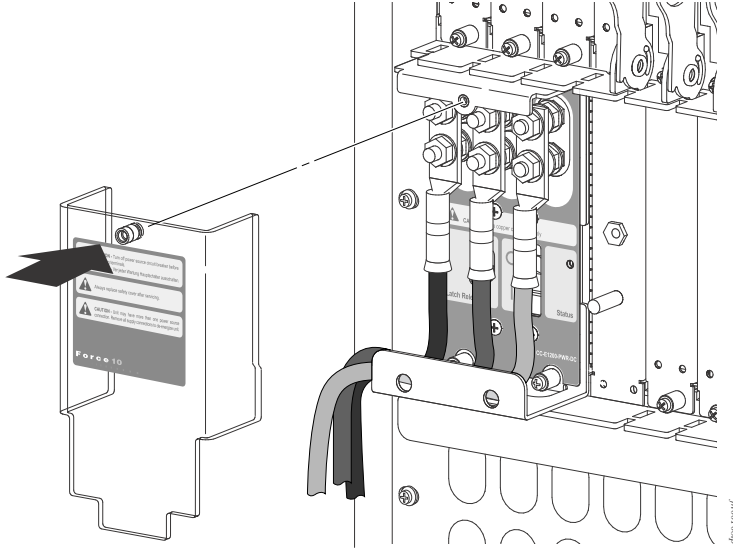

Figure 8-6. DC PEM with Connections in Place



Step	Task (<i>continued</i>)
8	Replace the safety cover and tighten the captive screw with a #2 Phillips screwdriver (Figure 8-7).

Figure 8-7. Reinstalling the PEM Safety Cover



- 9 Check that the over-current protector (located on the PEM front panel) is in the **OFF** position. Energize the remote power source. The Voltage LED should be green. If it is amber, the -48 VDC and Return cables are connected incorrectly or are reversed.
- 10 Go to [DC Power Supply and Fan Operability Test](#), next, to complete the installation.

DC Power Supply and Fan Operability Test

After you have completed the fan tray and PEM installation, verify their operability by supplying power to the chassis and verifying the status LEDs.

NOTE: If there is a DC PEM failure, the entire PEM must be replaced. There are no field-serviceable parts inside the DC PEM unit.

Before you begin this power test, inspect your equipment rack and chassis. Verify that:

- Each PEM is properly installed and grounded.
- The safety covers are installed on each PEM.

WARNING: Prevent exposure and contact with hazardous voltages. Do not attempt to operate this system without the safety cover provided with each DC PEM.

- Your power cables connect to an appropriate DC supply in a manner that complies with your local electrical codes. For DC systems, a Main Disconnect must be provided.
- On the DC PEM(s), use a voltage meter to verify power on the cables. Also verify that the Voltage LED is green.
- A power supply blank is installed in any empty slot.

- Two fan trays are installed.

To test the power supplies and fan trays:

Step	Task
1	With the fan trays and DC PEMs installed, power on the system. <ul style="list-style-type: none"> • Flip the over-current protector (located on the PEM front panel) to the ON position.
2	Power Supply Status LEDs should be green. The LED is unlit when the system is off or blinking green when the system is booting. During boot, the blinking green LED may switch to blinking amber until the RPM boot is complete. <ul style="list-style-type: none"> • Check that the units are properly installed and are plugged into the correct slot. • Verify the power source • If the LED remains unlit or is blinking amber after the system has booted, replace the power supply.
3	Both fan tray LEDs should be green (online). blinking green fan tray LED indicates that the system is booting. During boot, the blinking green LED may switch to blinking amber until the RPM boot is complete. If a fan tray is not operating properly or air is not flowing through the chassis: <ul style="list-style-type: none"> • Power off the chassis at the remote power source. • Ensure that all fan trays are properly installed. • Verify the remote power source. • If a fan tray LED is unlit or is blinking amber after the system has booted, replace the fan tray.
4	After you have verified the power and fan operability, power off the chassis to continue the installation process.
5	De-energize the Main Disconnect and flip the over-current protector to the OFF position.
6	Verify that the LEDs are not lit.

Installing RPMs, Line Cards, and SFM3s

This chapter provides instructions for installing cards into the E1200 AC or DC chassis. It contains the following sections:

- [Unpacking an RPM or Line Card](#)
- [Installing Line Cards and RPMs](#)
- [Preparing and Installing RPMs and Line Cards](#)
- [RPM Label and LEDs](#)
- [Installing Switch Fabric Modules \(SFM3s\)](#)
- [Line Card Cable Management Systems](#)

Unpacking an RPM or Line Card

 **WARNING:** Electrostatic discharge (ESD) damage can occur when components are mishandled. Always wear an ESD-preventive wrist or foot-heel ground strap when handling RPMs, SFM3s, or line cards. Connect your ESD strap to the grounding plug located on the front of the chassis. After you remove the original packaging, place RPMs, SFM3s, and line cards on an antistatic surface.

 **WARNING:** Do not supply power to your E1200 system until the power supplies and fan tray(s) are installed and verified, and RPMs, SFM3s, line cards, and any blank panels are installed.

Force10 Networks recommends that you keep all components in the original packaging until you are ready to install them.

Important Points to Remember

- Do NOT remove the cards from their protective bags until you are ready to install them in a chassis.
- When you are ready to install the cards, unwrap and install one card at a time.
- When you are ready to install the cards, unwrap and install one card at a time, starting with the right-most slot (Slot R1 for RPMs and line cards, SFM Slot 2, Slot 5 or Slot 8 for SFMs) ending with the left-most slot (Slot 0 for line cards, and SFM Slot 0, Slot 3 or Slot 6 for SFMs)

Installing Line Cards and RPMs

At a minimum, the E1200 requires one RPM and one line card to operate.

 **CAUTION:** Any slot not filled with a line card or RPM must be filled with a blank to ensure adequate cooling and EMI containment.

RPMs

The E1200 system requires the installation of at least one RPM, although two are recommended for redundancy. RPMs are designed to be installed in either the center R0 or R1 slots. Since FTOS searches for an RPM in slot 0 first, Dell Force10 recommends you install your RPM in slot 0 when only running with one RPM. Do not force RPMs into line card slots. RPMs are keyed differently than line cards to prevent improper installation.

The E1200 system requires the installation of at least one RPM, although two are recommended for redundancy. RPMs are designed to be installed in either the R0 or R1 slots. Do not force RPMs into line cards slots. RPMs are keyed differently than line cards to prevent improper installation.

You can hot-insert a second RPM into a running system without performance interruption or software intervention. A second RPM for redundant functionality provides uninterrupted operability if the system transitions from the active RPM to the standby RPM. The standby RPM constantly performs updates and receives the same configuration information received by the active RPM. The standby RPM also performs diagnostics on its subsystems. In the event of a failover, the standby RPM immediately takes over and resumes the control activities that the active RPM was performing. [Installing a Second RPM on page 47](#) provides more information on the second RPM.

The RPM Major and Minor alarm LEDs are controlled by software which sets the threshold levels for triggering the different stages of alarms.

Line Cards

Your E1200 configuration requires a at least one line card. Line cards are hot-swappable. The line card ports provide external interface functions for connections to other systems (for example, a router or switch). Line cards have an onboard CPU for line card management which updates packet forwarding information, obtains statistical information, and performs synchronization tasks with the RPM, as well as at least one Dell Force10 custom-built ASIC.

Line Card Port Numbering

There are 14 line card slots available in the E1200 chassis. Line cards are installed in slots 0 through 13. Ports on line cards are numbered from the top, starting from 0 (see [Figure 9-1](#)). The actual number of ports on a line card depend on the type of line card installed. Refer to the installation documentation included with the line card itself.

Figure 9-1. Line Card Numbering

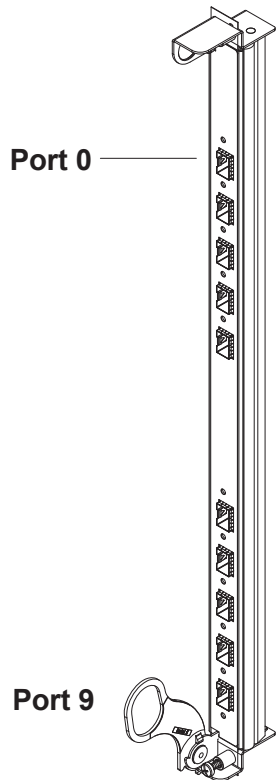

Blank Panels

CAUTION: To avoid a chassis over-temperature condition, install blanks for RPMs, SFM3s, and line card slots not in use. Always replace cards or blanks immediately.

Blank panels for RPMs, SFM3s, and line cards must be installed in empty slots to control airflow. If a slot is not filled a high-temperature condition might occur:

%CHMGR-2-MINORTEMP: Minor alarm: chassis temperature high (SFM temperature reaches or exceeds threshold of 65C)

Blank panels are shipped with the system to ensure that all chassis slots are installed with operational modules or blanks.

Preparing and Installing RPMs and Line Cards

Installing an RPM into the E1200i RPMs, line cards, and blank panels are packaged in the same box. To prolong the life of the EMI seals, begin installing cards in the right-most slot (R1), filling the slots leftward (R0, then slot 6, then slot 5, and so on). Load the cards from **right to left**.

Figure 9-2. Installing Cards into the E600

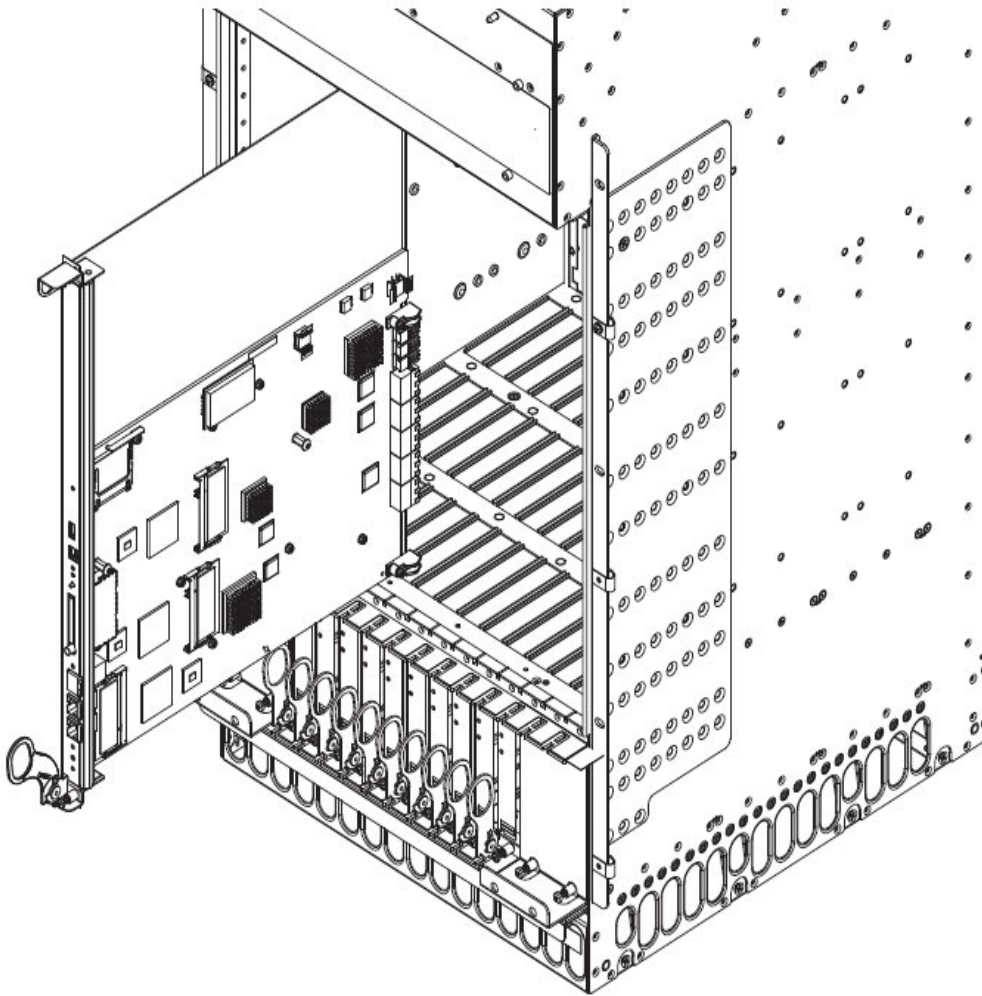
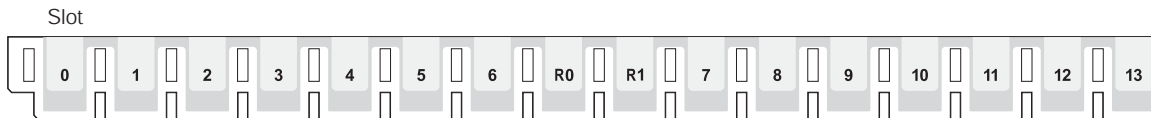



Figure 9-3. RPM and Line Card Slot Numbering Label



FN000298

CAUTION: It is important that you retain the packaging and installation order of the cards. Install cards from right to left, beginning with R1 slot.

To install line cards and RPMs:

Step	Task
1	Remove the line card from its box and carefully remove the line card from the anti-static packaging.
2	Align the RPM with the guide and gently slide it into the slot until you feel the connectors engage with the chassis backplane.  NOTE: Hold the card by the edges. Avoid touching the printed circuit board and connector pins. Extend the ejector levers before you insert the card into the slot.
3	Remove the card from the box. Remove the card from the anti-static bag.
4	Rotate the levers to seat the card in place.
5	Secure card and blanks in place by tightening the top and captive screws on each card.
6	Follow the same installation procedure for the remaining cards and slots, in the appropriate order.

 **NOTE:** The blank panels do not have board components or connector pins. Align the blank with the guides and gently slide toward the backplane.

Installing a Second RPM

 **NOTE:** If your system contains two RPMs, both RPMs must contain the same software image.

Install a second RPM either before the system is powered on or after the Primary RPM is up and stable. After the second RPM is installed, wait several seconds until the connection between the two RPMs is established before configuring any commands. Below is an example of the messages that should appear:

```
%POLLGR-2-ALT_RPM_STATE: Alternate RPM is present
```

```
%IRC-6-IRC_COMMUP: Link to peer RPM is up
```

```
%RAM-6-RAM_TASK: RPM1 is in Standby State.
```

Once the link between the two RPMs is established, copy the running configuration to the startup configuration.

RPM Label and LEDs

Table 9-1 describes the RPM LED states and the RPM front panel. RPMs control the routing and switching functions for the entire E600/E1200 system. The E600/E1200 operates with a minimum of one RPM module. You can hot-insert a second RPM into a running system without performance interruption or software intervention. A second RPM for redundant functionality provides uninterrupted operability if the system transitions from the primary RPM to the secondary (standby) RPM. The secondary RPM constantly performs updates and receives the same information received by the primary RPM. The secondary RPM also performs diagnostics on its subsystems. In the event of a switchover, the secondary RPM immediately takes over and resumes the control activities that the primary RPM was performing.

Table 9-1. RPM LEDs

Section	Label	Description
---------	-------	-------------

Table 9-1. RPM LEDs

Management	10/100 Ethernet	L: Green: link is up A: Green: activity on port
Alarms	Major	Red: a critical condition exists, such as a severe overtemperature condition, a fan tray failure, an overcurrent condition in a power supply, or an out-of-tolerance voltage. The RPM LEDs are controlled by software which sets the threshold levels for triggering the different stages of alarms. Unlit: no major conditions.
	Minor	Amber: a serious condition exists, such as an overtemperature condition, a single fan failure, or a line card failure. The RPM LEDs are controlled by software, which sets the threshold levels for triggering the different stages of alarms. Unlit: no minor alarm conditions.
	LT	Allows you to test the operability of LEDs to verify that they are able to light. Press the LT button to temporarily illuminate the LEDs on the RPM.
Flash		Green: flash memory card is in the process of a read or write process. Do not remove the flash card when the In Use LED is lit. Unlit: not in use.
Primary		Green: primary Unlit: secondary (or standby)
Status		This is a bi-color LED. Green: operational Amber: fault detected Flashing green: booting Unlit: in secondary mode or power is off
Location		This LED is either lit blue or is unlit. It is used to locate a chassis and is turned on via the command line interface.

Line Card LEDs

Line card LEDs are described in the documentation specific to each line card. Refer to the installation documentation that came with the card for to understand LED appearance and meaning.

Installing Switch Fabric Modules (SFM3s)

A minimum of 8 SFM3s are required in order for the E1200 system to operate properly. Nine SFM3s are required for full line rate, while ten SFM3s creates full redundancy. The chassis allows up to ten SFM3s; when all 10 are installed, any two may be removed, and the chassis still operates normally.

SFM3s (catalog # CC-E-SFM3) carry user traffic between line cards or between RPMs and a line card. SFM3s plug directly into the backplane, which provides high-speed access to the line cards. The switch fabric receives user data packets and redirects them to the appropriate destinations according to the routing information.

CAUTION: If you are not operating your system with a redundant (tenth) SFM3, you must install an SFM3 blank to avoid overheating and ensure EMI containment.

Step	Task
1	Remove an SFM3 from the anti-static packaging.
2	Align the SFM3 with the guide and gently slide it into the slot until you feel the connectors engage with the chassis backplane. NOTE: Hold the SFM3 by the edges. Avoid touching the printed circuit board and connector pins. Extend the ejector lever before you insert the SFM3 into the slot.
3	Rotate the lever to seat the backplane connectors and card in place.
4	Secure each SFM3 in place by tightening the captive screw.
5	Continue the process for the remaining SFM3s.
6	Align any blank panels with the guides and gently slide toward the backplane. Secure each blank panel by tightening the single captive screw.

NOTE: If you are not operating your E1200 system with redundancy, your SFM3 package will include blank panels. Blanks are slot covers that have no board components or connector pins.

SFM3 Front Panel and LEDs

Table 9-2 illustrates the SFM3 front panel and LEDs.

Table 9-2. SFM3 Front Panel and LED Descriptions

	LED	Description
 <p>The diagram shows a vertical SFM3 front panel. At the top, it is labeled 'CC-E-SFM3'. Below the label, there are two circular LEDs. The top one is labeled 'Active' and the bottom one is labeled 'Status'.</p>	Active	Green: active and passing traffic Unlit: in standby mode
	Status	Green: operational Flashing Amber: communication timeout or booting Amber: fault detected Unlit: no power

Line Card Cable Management Systems

Dell Force10 provides a variety of E1200 chassis cable management systems to manage your fiber optic and auxiliary cables connecting to line cards. For details, see the Dell Force10 price list. For installation instructions, see the instructions that come with the specific cable management system.

RPM Ports and Cables

This chapter describes standard RPM cables and adapter pin assignments for the E1200i AC and DC systems. It contains the following sections:

- [RPM Ports](#)
- [Cable and Adapter Pin Assignments](#)
- [Accessing the 10/100 Ethernet Management Port](#)

This section provides the following:

- [RPM Ports](#)
- [Cable and Adapter Pin Assignments](#)
- [Accessing the 10/100 Ethernet Management Port](#)

RPM Ports

There are three ports on the RPM. They are labeled and described as:

- **Console.** A Universal Asynchronous Receiver/Transmitter (UART) port with an RJ-45 jack, is used for system configuration and monitoring. Modem connections are not supported on this port.
- **Auxiliary.** A UART port with an RJ-45 jack, allows modem access to the E1200 system from a remote location.
- **10/100 Ethernet.** A 10/100 Ethernet port is the Management port, which is a channel to download images and manage the system, as well as FTP and Telnet operations. You must provide a RJ-45 Ethernet cable to connect to the Ethernet receptacle.

Connecting the Console and Auxiliary Ports

 **NOTE:** Attach an ESD-preventive wrist strap and connect the leash to the ESD connection on the front of the E1200 chassis. Always wear an ESD-preventive wrist or foot-heel ground strap when handling components.

 **NOTE:** Always wear an ESD-preventive wrist or foot-ground strap when handling components.

The console and auxiliary ports are asynchronous serial ports. If you connect a device to these ports, it must be capable of asynchronous transmission. Your terminal or terminal emulation mode must be set to VT100 with the following settings:

- 9600 baud rate (to avoid autobaud input, the default is set to a 9600 bps baud rate)
- No parity
- 8 data bits
- 1 stop bit

- Window Terminal Emulator option set to **NO**
- 24 lines X 80 characters
- No flow control (console port only)
- Hardware flow control (RTS/CTS) (for auxiliary port only)

Cable and Adapter Pin Assignments

Use the E1200 Console port on the RPM to connect to a terminal port, PC serial port, or a terminal server to configure and monitor your system. Use the E1200 Auxiliary port on the RPM to connect to a modem.

Both the Console and Auxiliary port are RJ-45 ports. [Figure 10-1](#) displays the pinouts in an RJ-45 port.

Figure 10-1. Pinout for an RJ-45 Connector End Adaptors

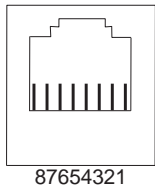

[Table 10-1](#) displays the RJ-45 console port pin assignments. [Table 10-2](#) displays the RJ-45 auxiliary port pin assignments.

Table 10-1. Console Port (RJ-45) Pin Assignments

Pin	Signal	Input/Output
1	NC (unused)	-
2	DTR	Output
3	TxD	Output
4	GND	-
5	GND	-
6	RxD	Input
7	DSR	Input
8	NC (unused)	-

Table 10-2. Auxiliary Port (RJ-45) Pin Assignments

Pin	Signal	Input/Output
1	RTS	Output
2	DTR	Output
3	TxD	Output
4	GND	-
5	GND	-
6	RxD	Input

Table 10-2. Auxiliary Port (RJ-45) Pin Assignments

Pin	Signal	Input/Output
7	DSR	Input
8	CTS	Input

Accessing the Console with a DB-9 Adapter

You can connect to the console using a RJ-45 to RJ-45 rollover cable and a RJ-45 to DB-9 female DTE adapter (labeled “TERMINAL”) to a terminal server (for example, PC). [Table 10-3](#) lists the pin assignments.

Table 10-3. Pin Assignments Between the E1200 Console and a DTE Terminal Server

E1200 Console Port	RJ-45 to RJ-45 Rollover Cable		RJ-45 to DB-9 Adapter	Terminal Server Device
Signal	RJ-45 Pinout	RJ-45 Pinout	DB-9 Pin	Signal
RTS	1	8	8	CTS
DTR	2	7	6	DSR
TxD	3	6	2	RxD
GND	4	5	5	GND
GND	5	4	5	GND
RxD	6	3	3	TxD
DSR	7	2	4	DTR
CTS	8	1	7	RTS

Accessing the Console with a DB-25 Adapter

You can connect to the console using an RJ-45 to RJ-45 rollover cable and RJ-45 to DB-25 female DTE adapter. [Table 10-4](#) lists the pin assignments.

Table 10-4. Pin Assignments Between E1200 Console and DB-25 Adapter

E1200 Console Port	RJ-45 to RJ-45 Rollover Cable		RJ-45 to DB-25 Modem Adapter	Terminal Server Device
Signal	RJ-45 Pinout	RJ-45 Pinout	DB-25 Pinout	Signal
RTS	1	8	5	CTS
DTR	2	7	6	DSR
TxD	3	6	3	RxD
GND	4	5	7	GND
GND	5	4	7	GND
RxD	6	3	2	TxD
DSR	7	2	20	DTR
CTS	8	1		RTS

Accessing the Auxiliary Port by Modem

You can access the auxiliary port using a dial-up modem using an RJ-45 to RJ-45 rollover cable and RJ-45 to DB-25 male DCE adapter (labeled “MODEM”). [Table 10-5](#) lists the pin assignments.

Table 10-5. RJ-45 to DB-25 Adapter Pin (Modem) Assignments

E1200 Auxiliary Port	RJ-45 to RJ-45 Rollover Cable		RJ-45 to DB-25 Modem Adapter	Modem
Signal	RJ-45 Pinout	RJ-45 Pinout	DB-45 Pinout	Signal
RTS	1	8	4	RTS
DTR	2	7	20	DTR
TxD	3	6	3	TxD
GND	4	5	7	GND
GND	5	4	7	GND
RxD	6	3	2	RxD
DSR	7	2	8	DCD
CTS	8	1	5	CTS

Accessing the 10/100 Ethernet Management Port

Configure the 10/100 Ethernet management port, labeled **10/100 Ethernet** on the primary RPM card in order to obtain network access capability, such as downloading a runtime image onto your system. You can connect this port to an Ethernet hub or FastEthernet port on a router.

Table 10-6. 10/100 Ethernet Management Port LEDs

Label	Description
L (Link)	Lit: Link is up Unlit: No connection
A (Activity)	Lit: Activity on port Unlit: No activity

Universal Serial Bus Ports

There are 2 USB ports, labeled A and B. The A port is a host port and allows a user to install a flash memory stick for use as external flash. It provides some amount of power at 5V. The B port is a device port and allows a user to hook up an external PC for console access.

Powering Up

This chapter provides instructions for powering up your E1200 AC or DC system after you have installed all the chassis components and made your power and network connections. It covers the following topics:

- [Preparation](#)
- [Supplying Power - AC](#)
- [Supplying Power - DC](#)
- [Booting to the CLI Prompt](#)

Preparation

 **NOTE:** Make sure that the switch on the **remote power source** is in the **OFF** position until you are ready to supply power to the chassis.

Before you supply power to your chassis, re-inspect your equipment rack and chassis.

Verify that:

- The equipment rack is properly secured and grounded.
- The chassis is bolted and secured into your equipment rack.
- The chassis is grounded.
- Each power supply module is properly installed and secured.
- The AC-Cord Retainer is installed on AC systems.
- The power switch is in the **OFF** position for DC systems, and **STANDBY** for AC systems.
- Power cables connect to a compliant remote power source.
- Both fan trays are installed and secured.
- All line cards, RPMs, and SFM3s are properly installed and secured.
- All chassis slots are filled. Blank panels and covers are installed in all empty slots.

 **WARNING:** Leakage Current (High Touch Current): The AC power cords are secured to the power inlet using the provided bracket. The power cord plugs must be secured to the building outlets by the chassis installer or a qualified electrician.

Supplying Power - AC

Step	Task
1	Flip the REMOTE power switch to the ON position.
2	Remove the card from the box. Remove the card from the anti-static bag.
3	Flip the On/Standby switch to the ON position.
4	The Status LED for each power supply should be green (online). If a power supply's LED is not lit or is amber: <ul style="list-style-type: none"> • Ensure that the unit is properly installed. • Verify the power source. • If the power supply's LED remains unlit, power off the remote power source and replace the unit.
5	Both fan tray LEDs should be green (they may flash green, or amber during a long boot). Verify that air is flowing through the chassis. If a fan tray is not operating properly or air is not flowing through the chassis: <ul style="list-style-type: none"> • Power off the chassis at the remote power source. • Ensure that the fan tray is properly installed. • Verify the power source. • If the fan tray LED remains unlit on power-up, replace the fan tray.

To turn the chassis power off, flip the On/Standby switch to the **Standby** position.

 **NOTE:** The AC power supplies status LEDs will remain lit and the power supply fans will continue to operate, even though DC power to the backplane has been turned off.

Supplying Power - DC

Step	Task
1	Flip the REMOTE power switch to the ON position.
2	Remove the card from the box. Remove the card from the anti-static bag.
3	The Status LED for each power supply should be green (online). If a power supply's LED is not lit or is amber: <ul style="list-style-type: none"> • Ensure that the unit is properly installed. • Verify the power source. • If the power supply's LED remains unlit, power off the remote power source and replace the unit.
4	Both fan tray LEDs should be green (they may flash green, or amber during a long boot). Verify that air is flowing through the chassis. If a fan tray is not operating properly or air is not flowing through the chassis: <ul style="list-style-type: none"> • Power off the chassis at the remote power source. • Ensure that the fan tray is properly installed. • Verify the power source. • If the fan tray LED remains unlit on power-up, replace the fan tray.

Booting to the CLI Prompt

After you supply power to the system, the following should occur:

- During bootup, power is removed temporarily from all line cards and SFM3s. This is expected behavior.
- Both fan trays should be operating. The fan tray and SFM3 LEDs might flash amber during bootup.

- The green (online) LEDs for the fan trays, Power Supplies, RPMs, SFM3s, and line cards should be lit and remain lit as long as the system is receiving power and is operational.
- The fans should be operating.
- The green (online) fan tray, power module, RPM, SFM, and line card LEDs should be lit and remain lit as long as the system is receiving power and is operational.

When you supply power to the E1200 system, the system performs a series of power-on self tests. RPM, line card, and SFM3 LEDs blink as the diagnostic programs run. No user interaction is required at this point. Observe the process on your console monitor. When the boot process is complete, the card LEDs remain online (green) and the console monitor displays the Command Line Interface (CLI) prompt.

 **NOTE:** Do not press any keys or control sequences at any time during the boot process. Doing so may cause the boot process to terminate.

Refer to the *FTOS Configuration Guide* for initial configuration procedures and configuration instructions.

Booting from the BOOT_USER Prompt

The initial boot operation automatically brings up the system to the runtime CLI. To interrupt the automatic boot process, issue a break key sequence (CNTL^). The console monitor will display the default BOOT_USER # prompt. Refer to [Chapter A, System Boot](#) for instructions to continue the boot process.

Removing and Replacing Components

This chapter provides instructions for removing and replacing E1200 AC and DC components. It covers the following topics:

- [Removing and Replacing Fan Trays](#)
- [Removing and Replacing AC Power Supplies](#)
- [Removing and Replacing DC Power Supplies](#)
- [Removing and Replacing RPMs, Line Cards, or SFM3s](#)
- [Removing and Replacing the Air Filter](#)

When a component fails, the E1200 system triggers major or minor alarm LEDs (located on the RPM), sends events to the SNMP trap and show alarms table, and disables or changes component Status LEDs. Refer to [Chapter B, Alarms](#) for more information on alarms.

Removing and Replacing Fan Trays

In the event of a fan tray failure, signified by an amber LED, an SNMP trap, or major alarm event, the entire fan tray must be replaced. If one or more fans within a fan tray fail, the system generates a minor alarm and an SNMP trap.

The fan trays are hot-swappable. To remove or replace the fan tray, you must have access to the rear of the chassis and be able to pull the fan tray completely out of the slot (at least 20 inches).

To remove or replace a fan tray:

Step	Task
1	Prior to removing a fan tray, turn the screw latch counter-clockwise (with a flathead screwdriver) one quarter of a turn to unlock the fan tray. (Figure 12-1).
2	Grip the handle and pull the fan tray out approximately one inch from the chassis. Wait until the fan blades stop rotating, then remove  WARNING: Keep fingers clear of rotating fan blades.
3	Prior to inserting a new fan tray, fully turn (with a flathead screwdriver) the screw latch counter-clockwise until the fan tray latching mechanism retracts into the fan tray.
4	Insert the fan tray into the chassis. Guide the tray firmly into the slot until it stops and the handle end is flush with the chassis rear.
5	To secure the fan trays into place, turn the screw latch clockwise to tighten the latching mechanism. (see Figure 12-1)

Figure 12-1. Securing the Fan Tray Screw Latch

Removing and Replacing AC Power Supplies

If you are operating your E1200 AC chassis with redundant Power Supplies, you can install, remove, or replace a Power Supply without affecting system operation. If you are operating your E1200 AC system with only three Power Supplies (the minimum), you must *completely* power off the system.

- 🔧 **NOTE:** If there is a Power Supply failure (Power Supply LED is not lit or major alarm LED is lit), the entire Power Supply Module must be replaced. There are no field serviceable parts inside the Power Supply unit.
- ⚠️ **WARNING:** Do not remove the AC-Cord Retainer until the power supplied by the remote power source is OFF.
- 🔧 **NOTE:** The On/Standby switch disconnects power to the rest of the chassis from *all* 6 AC power supplies. When the AC cord is attached, power supply fans will spin, and the LEDs will indicate status while the On/Standby switch is in Standby.
- 🔧 **NOTE:** AC Power Supplies may be replaced without removing the AC-cord retainer or the AC cords.

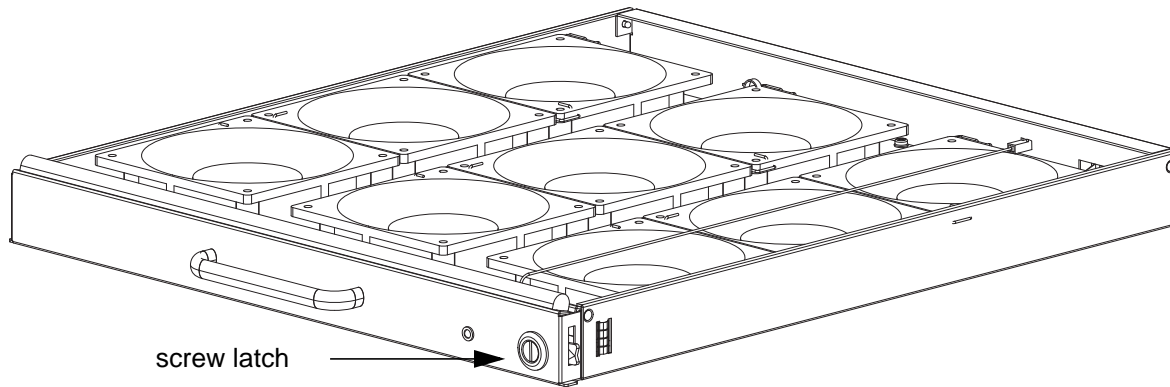
Remove an AC Power Supply in a non-redundant installation

Step	Task
1	Unplug the network interface cables connected to the line card or RPM.
2	Activate the disconnect switch at the Main power source or disconnect the AC cord at the remote power source.
3	Grip the handle and squeeze the thumb latch.
4	Slide the Power Supply out of the slot.
5	If you are replacing the Power Supply, go to Installing AC Power Supplies on page 29 .

Remove an AC Power Supply in a redundant installation

Step	Task
------	------

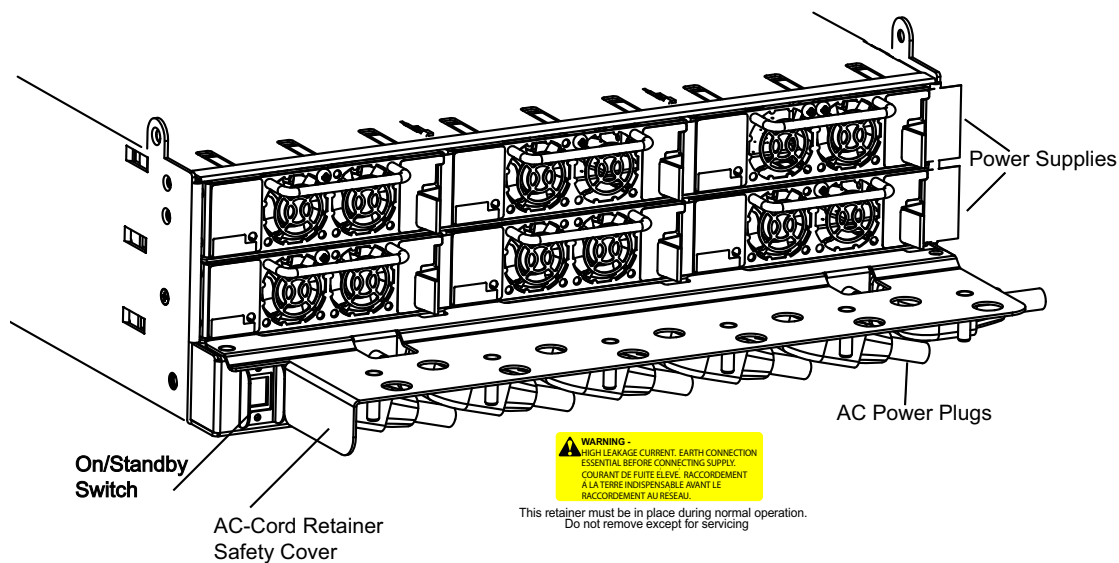

- 1 Tilt the AC-cord Retainer Safety cover approximately 15° and gently slide the cover away from the chassis.
- 2 Grip the handle and squeeze the thumb latch.
- 3 Slide the Power Supply out of the slot.
- 4 If you are replacing the Power Supply, go to [Installing AC Power Supplies on page 29](#).

Removing and Replacing DC Power Supplies

If you are operating your E1200 DC chassis with redundant Power Supplies, you can install, remove, or replace a Power Supply without affecting system operation. If you are operating your E1200 DC system with only one Power Supply (the minimum), you must completely power off the system.

NOTE: If there is a Power Supply failure (Power Supply LED is not lit or major alarm LED is lit), the entire Power Supply Module must be replaced. There are no field serviceable parts inside the Power Supply unit.

Remove a DC Power Supply

Step	Task
1	Ensure that the remote power source is in the OFF position and that the PEM status light is off. <ul style="list-style-type: none"> • PEM 0 connects to remote power source 0. • PEM 1 connects to remote power source 1.
2	Loosen the retaining screw and remove the PEM safety cover.

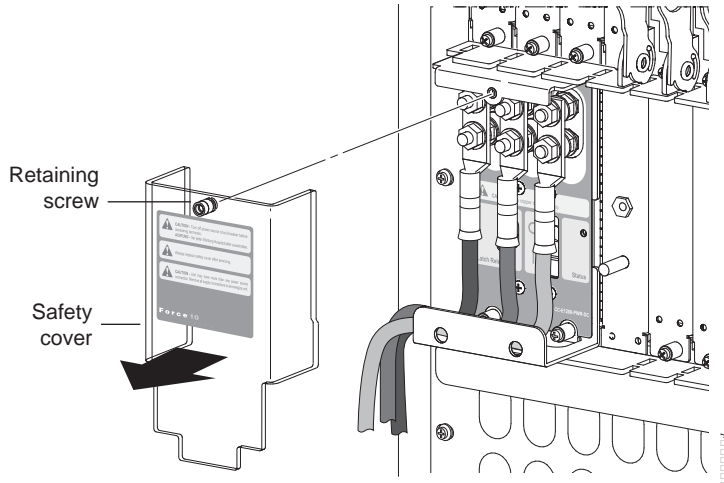



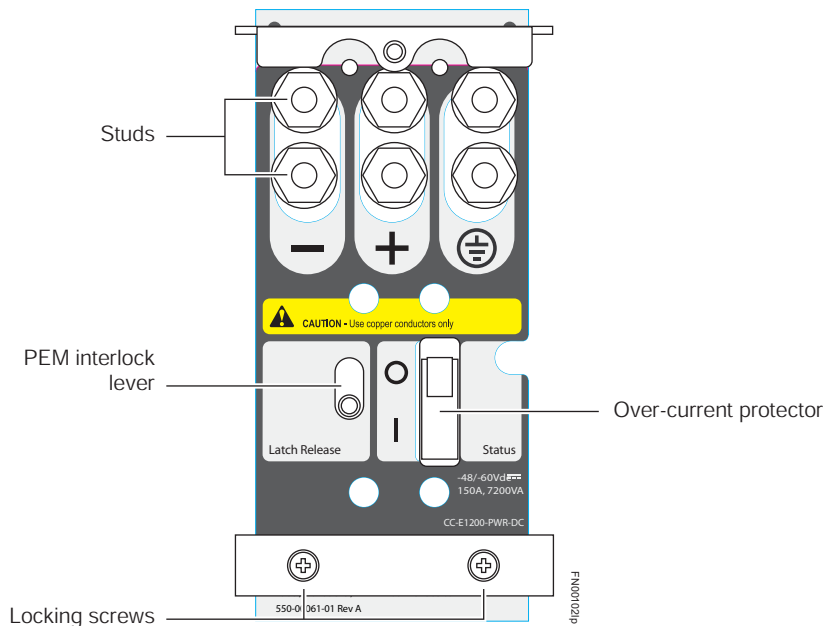





- 3 Switch the Over Current Protector (located on the PEM front panel) to the **OFF** position.



- 4 Loosen the Locking screws.
- 5 Lift and hold the PEM interlock lever to release the PEM
- 6 While holding the interlock lever up, using the bottom handle, pull the PEM straight out of the slot.

Removing and Replacing RPMs, Line Cards, or SFM3s

-  **WARNING:** Do not remove a panel blank unless you are ready to install a line card, RPM, or SFM3 into that slot. If you remove a card, immediately replace the empty slot with a panel blank. Blanks are required to control airflow and electromagnetic interference.
-  **WARNING:** Electrostatic discharge (ESD) damage can occur when components are mishandled. Always wear an ESD-preventive wrist or foot-heel ground strap when handling RPMs, SFM3s, or line cards. (Connect the ESD strap to the grounding plug located on the front of the chassis.)
-  **WARNING:** After you remove the original packaging, place RPMs, SFM3s, and line cards on an antistatic surface.
-  **NOTE:** If you operate your E1200 without redundant RPMs, the system enters a software-defined power-down state when you remove the only RPM for replacement.
-  **NOTE:** Your E1200 system will not function properly with fewer than eight SFM3s.
-  **NOTE:** If you operate your E1200 without redundant RPMs, the system enters a software-defined power-down state when you remove the only RPM for replacement.
-  **NOTE:** Your E1200 system will not function properly with fewer than eight SFMs. The line cards will not forward information to a non-operational or absent SFM.
-  **NOTE:** Use the optical connector insertion/removal tool to insert and remove fiber cables from 1GE cards with small form factor ports. A optical Connector insertion/removal tool is shipped with each card that is ordered separately.

You can add, replace, or remove modules without interrupting the system power or system operations. RPMs, line cards, and SFM3s are hot-swappable. The E1200 system generates major alarm events for high temperatures (over 75°C) and module failures depending on the module and whether or not it is redundant. Minor alarms are generated for component temperatures over 65°C and 75°C for line cards. SNMP traps are sent for both alarm types. Refer to [Chapter B, Alarms](#) for more details.

Removing and Replacing line cards or RPMs

To remove and replace E1200 line card or RPM modules:

Step	Task
1	Unplug the network interface cables connected to the line card or RPM.
2	Loosen the captive screws and pull the ejector levers simultaneously toward you to disengage the backplane connections.
3	Slide the card out of the slot and store the cards in the original antistatic packaging.
4	If you are immediately installing a replacement card, align the new card with the guide, and gently slide the card into the slot until you feel the connectors engage with the chassis backplane. If you are not planning to install a new card immediately, install a blank panel.

Step	Task (<i>continued</i>)
5	<p>If you are installing a line card, follow these procedures:</p> <ul style="list-style-type: none"> • If you are hot-swapping (replacing the line card with the same card type), no additional configuration is required. • If you are installing a different line card type, enter, in Configuration mode, the following command: linecard <i>number card-type</i>, where <i>number</i> is a slot number from 0 to 13, and <i>card-type</i> is the five-character code for the card type. • If you are replacing the line card with a blank panel, delete the line card information from the configuration by entering: no linecard
6	<p>If you are <i>not</i> operating your system with redundant cards (with only one line card, one RPM, and eight SFM3s) you power off your system until the cards are replaced.</p>

Removing and Replacing SFM3s

To remove and replace an SFM3:

Step	Task
1	Loosen the captive screw and pull the ejector lever towards you to disengage the backplane connections.
2	<p>Slide the card out of the slot and store in the original anti-static packaging. System messages appear on the console, including the following:</p> <pre>%TSM-6-SFM_REMOVE: Removed SFM</pre> <p>Wait 5 to 10 seconds to install a new SFM3 or reinsert an SFM3. *</p>
3	Remove the new SFM3 from the antistatic packaging.
4	<p>Align the new SFM3 with the guide and gently slide the card into the slot until you feel the connectors engage with the chassis backplane.</p> <p> NOTE: Hold the SFM3 by the edges. Avoid touching the printed circuit board and connector pins. Extend the card lever before you insert the card into the slot.</p>
5	Rotate the lever to seat the backplane connectors and SFM3 in place.
6	Secure the SFM3 in place using the provided screw.
7	<p>If you are not operating your E1200 system with redundancy, replace the empty slot with a filler panel blank. Blanks do not have board components or connector pins. Align the blank with the guides and gently slide toward the backplane. Rotate the lever to secure the blank in place.</p>

 **NOTE:** If you mistakenly insert an SFM3 too quickly after removing it, traffic flow is interrupted. To correct the situation, remove an active SFM3 or the standby SFM3, wait several seconds, and reinsert. System messages stating that the active interfaces' status changed and the switch fabric is up appear when an SFM3 is inserted correctly and traffic is flowing.

To remove and replace a fan tray:

- 1 Loosen the captive screws on the fan tray with a #2 Phillips screwdriver.
- 2 Prior to removing a fan tray, turn the screw latch counter-clockwise (with a Phillips screwdriver) until the fan tray latching mechanism retracts into the fan tray.
- 3 Grip the handle and pull the fan tray halfway out from the chassis. Wait 30 seconds until the fan blades stop rotating then remove.

- NOTE:** Always keep your fingers away from rotating blades.
- 4 Prior to inserting the fan tray replacement, turn the screw latch counter-clockwise (with a Phillips screwdriver) until the fan tray latching mechanism retracts into the fan tray. Insert the fan tray into the chassis at a slightly upward angle. Guide the tray firmly into the slot until you feel the connectors engage with the chassis backplane. Release the screw latch.
- 5 Tighten the captive screws.
- 6 Verify that the fan tray LED is lit green (online).

Removing and Replacing the Air Filter

A factory-installed air filter (Figure 12-2) is shipped with the E1200 system. The hot-swappable air filter prevents large particles, debris, and dust from entering and circulating through the system, and ensures proper air flow through the system. Filters should be inspected monthly and replaced every twelve months or as required.

WARNING: An improperly installed air filter will restrict air flow and will generate thermal problems throughout the chassis. Ensure the air filter is oriented correctly and seated securely in the slot.

WARNING: Do not operate without a filter for any longer than 30 minutes to avoid card over-temperature conditions.

To remove and replace the air filter:

Step	Task
1	Pull the air filter straight out of the chassis.
2	Rotate the replacement filter so that the front handle label is right reading.
3	Guide the filter firmly into the slot until it stops.

The E1200 air filter is hot-swappable. You do not need to turn the power off to the chassis to replace a filter. Filters should be inspected monthly and clean and replaced every six months.

Figure 12-2. Replacing the Air Filter

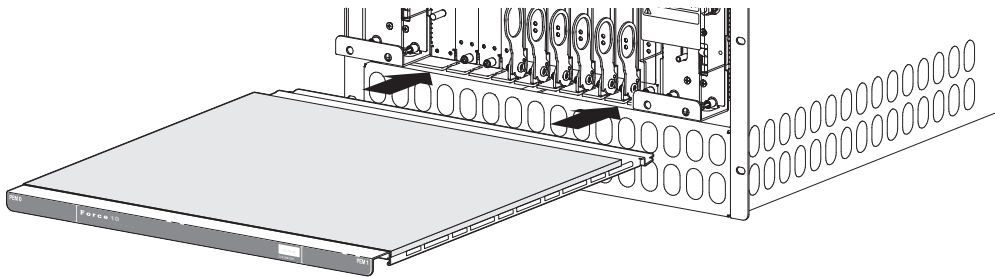

Using a Flash Memory Card

This appendix provides information about using an external flash memory card and contains the following sections:

- [External Flash Memory Card](#)
- [Inserting the External Flash Memory Card](#)
- [Removing the External Flash Memory Card](#)
- [Formatting an External Flash Card](#)
- [Copying Files to the External Flash](#)
- [Displaying Files Stored on the External Flash](#)
- [External Flash Memory Card](#)
- [Formatting an External Flash Card](#)
 - [Inserting the External Flash Memory Card](#)
 - [Removing the External Flash Memory Card](#)
- [Copying Files to the External Flash](#)
- [Displaying Files Stored on the External Flash](#)

External Flash Memory Card

Each RPM card is designed with a slot to accommodate an external flash memory card (slot0:). You can use a flash card to copy the image and configuration files for storage and backup purposes. For complex configurations, use the copies for other E1200 systems in your network. Configure your boot execution process to use the images stored on a flash card as the primary (active), secondary (standby), or default boot order preference. Optional external flash memory cards are shipped blank.

Inserting the External Flash Memory Card

 **NOTE:** Only insert the external flash before system boot or after the system has completed its boot and is run-time mode.

To install the flash memory card:

Step	Task
1	Press the ejector button to ensure it is in the extended position. Hold the flash card vertically (with the manufacturer's label on the left and the barcode on the right).
2	Gently insert the flash card into the primary RPM flash slot until the card is flush with the front panel. Do not force the flash card into the slot.
3	The In Use LED illuminates only during read or write operations.

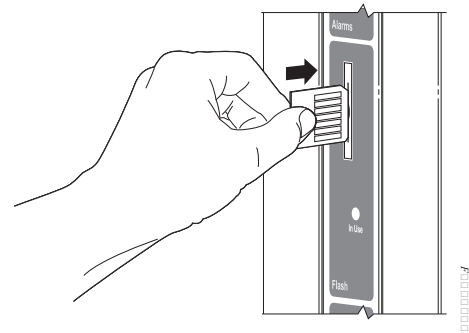

To install the flash memory card:

- 1 Hold the flash card vertically with the slanted edge on top and the connector end facing the slot.
- 2 Insert the flash card into the primary RPM flash slot until the card is completely seated with the connectors at the rear of the slot. Do not force the card into the slot. The slot is specifically tooled to prevent improper installation.
- 3 The In Use LEDs only illuminate during read or write operations.

Removing the External Flash Memory Card

To remove the flash memory card:

Step	Task
1	Gently depress the flash card in the slot. The card should partially pop out of the slot.
2	Remove the card and place it in an antistatic bag.

To remove the flash memory card:

- 1 Gently depress the flash card in the slot. The card should partially pop out of the slot.
- 2 Remove the card and place it in an antistatic bag.

Formatting an External Flash Card

New external flash cards must be formatted in the E1200 before use.

Flash cards used on systems other than the E1200 as well as cards formatted on PCs must be reformatted in the E1200 flash slot before they can be used. Similar to formatting a new diskette, formatting erases all information stored on the flash card.

To format the flash card:

Step	Task
1	Insert the flash card into the flash slot on the <i>primary</i> RPM.
2	In the EXEC CLI mode, enter <code>format slot0</code> :
3	The formatted flash card is ready to use.

- 1 Insert the flash card into the flash slot on the *primary* RPM.
- 2 In the EXEC CLI mode, enter `format slot0`:
- 3 The formatted flash card is ready to use.

Copying Files to the External Flash

Copy files to the flash when you want keep a backup image. The In Use LED illuminates during a read or write operation. Do not eject the flash card from the slot while this LED is lit.

To copy files to the external flash card use the following command:

Command Syntax	Command Mode	Purpose
<code>copy file-url1 file-url2</code>	EXEC Privilege	Configure the following parameters: <ul style="list-style-type: none">• <i>file-url1</i>: the file source• <i>file-url2</i>: enter <code>slot0://</code>

Displaying Files Stored on the External Flash

Flash cards can be used to copy and store system images, boot images, and configuration files. Optional flash memory cards are shipped blank.

To display files stored on a flash, use the following command:

Command Syntax	Command Mode	Purpose
<code>dir [filesystem]</code>	EXEC Privilege	Configure the following optional parameters to view files on the flash card: <ul style="list-style-type: none">• <i>filesystem</i>: enter either <code>flash:</code> for the internal flash or <code>slot0:</code> for the external flash. The default is <code>flash:</code> (the internal flash). To view the external flash, enter <code>dir slot0</code> :

Figure 13-1. dir Command Example

```
Force10#dir slot0:
Directory of slot0:

 1  -rwx      6478482   Sep 7 101 16:54:34  E1200i.BIN
```

FTOS supports up to a 40-character file name length, up to a 180-character local file path length, and up to a 256-character remote file path length.

System Boot

This appendix provides instructions to boot the E1200 AC and DC system from the BOOT_USER prompt.

The System Boot Process

System Boot

When you supply power to the E1200 system, the system performs a series of power-on self-tests. RPM, and line card Status LEDs blink during initialization. No user interaction is required as long as the boot process proceeds without interruption. Observe the process on your console monitor and note the message output on the display. When the boot process is complete, the RPM and line card Status LEDs remain online (green) and the console monitor displays the command line interface (CLI) prompt, Force10>.

The RPM cards in the E1200 system contain an internal flash memory card (flash:). This is the default storage area for the boot files and the startup configuration file. Upon system power up or a system reset, the boot process uses parameters stored in non-volatile random access memory (NVRAM) to boot the system.

Each RPM card is equipped with a slot for an external flash memory card (slot0:). You can copy the image files and configuration files to the external flash device on the *primary* RPM. You can also begin your boot process by accessing a remote server containing the boot image and system image files. When you configure your system to boot, you can specify the boot preference order: primary, secondary, or default in the BOOT_USER mode and the CLI mode.

 **NOTE:** The E1200 system supports up to a 40-character file name length, up to a 180-character local file path length, and up to a 256-character remote file path length.

For information about the flash memory card, refer to [Chapter 13, Using a Flash Memory Card](#).

Booting from the BOOT_USER Prompt

To get into the BOOT_USER mode, you can issue a break control sequence (CNTL^) to interrupt the automatic boot process or if you experience boot problems. This mode allows you to modify the parameters necessary to manage the boot process. Only console port access is enabled for the BOOT_USER mode.

To configure the chassis from the `BOOT_USER` prompt:

Step	Command	Task
1	<code>help</code> or <code>?</code>	<ul style="list-style-type: none"> • The <code>BOOT_USER #</code> prompt appears after an autoboot interruption. This is the default boot prompt, not the CLI prompt. • Enter <code>help</code> or <code>?</code> to display a list of available commands and syntax. • Enter <code>syntax help</code> to display syntax information and variable descriptions. • On some display output, you are given the option to continue the help screen display <code><cr></code> or to stop <code><q></code>. • You can abbreviate the boot commands by entering only the first letter of a command word. A matching algorithm displays the commands starting with the letter or letters you entered. For example, <code>b</code> displays the commands starting with the letter <code>b</code>, <code>boot change</code> and <code>boot selector</code>. Entering <code>sh</code> displays the syntax help information. • All commands are case insensitive.

- 2 Execute the following `SHOW` commands to display important boot information:
`show boot selector`

This command displays the boot ROM image currently selected and the most recently booted ROM image.

```

BOOT_USER # show boot selector

ROM BOOTSTRAP SELECTOR PARAMETERS:
=====
Current ROM bootstrap selector set to Bootflash partition A.

Last ROM bootstrap occurred from Bootflash partition A.

```

Step	Command	Task (continued)
------	---------	------------------

- 3 **show bootflash**
This command displays information about the current boot ROM.

```

BOOT_USER # show bootflash

GENERAL BOOTFLASH INFO
=====
Bootflash Partition A:
  Forcel0 Networks System Boot
  Copyright 1999-2007 Forcel0 Networks, Inc.
  ROM Header Version 1.0
  Official CP_IMG_BOOT, BSP Release 2.0.0.14
  Created Fri Nov  2 18:22:47 US/Pacific 2007

Bootflash Partition B:
  Forcel0 Networks System Boot
  Copyright 1999-2007 Forcel0 Networks, Inc.
  ROM Header Version 1.0
  Official CP_IMG_BOOT, BSP Release 2.0.0.14
  Created Fri Nov  2 18:22:47 US/Pacific 2007

```

- 4 **show bootvar**
This command displays the current operating system boot configuration parameters.

```



BOOT_USER # show bootvar

PRIMARY OPERATING SYSTEM BOOT PARAMETERS:
=====
boot device           : flash
file name             : /E1200i-x.bin

SECONDARY OPERATING SYSTEM BOOT PARAMETERS:
=====
No Operating System boot parameters specified!

DEFAULT OPERATING SYSTEM BOOT PARAMETERS:

```

Step	Command	Task <i>(continued)</i>
5	boot change {primary secondary default}	<p>If your configuration displays no preconfigured operating system boot parameters, use the boot change command to edit appropriate fields.</p> <ul style="list-style-type: none"> • The primary operating system boot parameters are used in the first attempt to boot the system. • The secondary operating system boot parameters are used if the primary operating system boot selection is not available. • The default operating system boot parameters are used if the secondary operating system boot parameter selection is not available. The default parameters always reside on the internal flash device (flash:). <p> NOTE: These parameters, as well as other boot parameters, can be modified in the CLI mode.</p> <p>When you enter the boot change command, you are prompted for a response.</p> <ul style="list-style-type: none"> • Enter a new parameter or press the ENTER key (carriage return) to accept the default parameter. • Enter . (period) to clear a field. • Enter - (dash) to edit a field above the current cursor position. <p> NOTE: When you enter a new parameter that extends beyond 80 characters, you cannot use the BACKSPACE key to correct any mistakes. If you make a mistake, you must re-enter the parameter.</p>

```

BOOT_USER # boot change primary

'.' = clear field; '-' = go to previous field

boot device           : flash
file name             : /E1200-3.x.bin

BOOT_USER # boot change default

'.' = clear field; '-' = go to previous field

```

Step	Command	Task (<i>continued</i>)
6	interface management port config 100m interface management port config 10m interface management port config auto- negotiate interface management port config no auto- negotiate interface management port config full-duplex interface management port config half-duplex interface management port config show	<ul style="list-style-type: none"> • (OPTIONAL) Use these commands to set the speed and duplex settings for the Management interface. The default setting is full-duplex and auto-negotiation. • Use the interface management port config show command to view the Management interface's physical settings.
7	show interface management ethernet interface management ethernet ip address <i>ip- address ip-address-mask</i>	<ul style="list-style-type: none"> • Use the show interface management ethernet command to display the IP address and network mask of the management Ethernet port. • If the show command output does not display configured IP address information, use the interface management ethernet ip address <i>ip-address ip-address-mask</i> command to set the IP address of the Management Ethernet port for network (ftp/tftp) operating system boot.
<div style="border: 1px solid black; border-radius: 15px; padding: 10px; margin: 10px auto; width: 80%;"> <pre> BOOT_USER # show interface management ethernet No IP address set for interface management ethernet 0/0! BOOT_USER # interface management ethernet ip address 1.2.3.4 255.255.0.0 Management ethernet 0/0 IP address: 1.2.3.4 255.255.0.0 BOOT_USER # show interface management ethernet </pre> </div>		
8	show default-gateway default-gateway <i>ip- address</i>	<p>(Optional) Use the show default-gateway command to view gateway information.</p> <p>If your server is on the same subnet, you do not need to configure a gateway parameter.</p> <p>If your server is not on the same subnet, use the default-gateway <i>ip-address</i> command to set the gateway IP address.</p>

Step	Command	Task (<i>continued</i>)
		<pre> BOOT_USER # show default-gateway No gateway IP address specified! BOOT_USER # default-gateway ip 1.2.3.5 Gateway IP address 1.2.3.5 BOOT_USER # show default-gateway </pre>
9	<p><code>dir flash:</code> <code>dir slot0:</code></p>	<p>Use the <code>dir flash:</code> command to list files stored on the internal flash device.</p> <p>Use the <code>dir slot0:</code> command to list files stored on the external flash device.</p>
		<pre> BOOT_USER # dir flash: Displaying files in flash: size date time name ----- 11187685 FEB-15-2002 05:37:58 e1200-.bin 11031398 FEB-23-2002 22:42:46 E1200-3.bin 9280984 FEB-17-2002 21:02:36 E1200-2.bin 10778521 FEB-18-2002 22:53:26 E1200-3.1.bin </pre>
10	<code>reload</code>	<p>Reload software.</p> <p>The autoboot program initializes and displays self-test results on the console screen.</p> <p> NOTE: Do not press break control sequence at any time during the boot/reboot process. Doing so causes the boot process to terminate.</p>
11	<code>Force10></code>	When the reboot completes, the CLI defaults to the EXEC mode.

Refer to the *<ItalicText>FTOS Command Line Interface Reference* for CLI configuration procedures and configuration instructions.

Alarms

The E1200 generates major and minor alarms for the following conditions:

- fan trays status
- Power Supply status
- fan tray status
- power supply status
- RPMs status
- high temperature on RPMs
- line cards status
- high temperature on line cards
- SFM3s status
- high temperature on SFM3s.

A major alarm is any fault that would render the E1200 non-functional.

A minor alarm is any fault that threatens the operation of the E1200.

You can monitor alarm conditions on the E1200 system through the console and LEDs. If you configure the SNMP command (`snmp-server enable traps envmon`), the FTOS also sends an SNMP trap.

In the E1200 system, alarms are logged for each occurrence, but the system may not send an event log for multiple occurrences. For example, whenever a module exceeds the shutdown threshold, the module shuts down. If more than one module exceeds the warning or high temperature thresholds within a five minute period, the system generates one event for all effected modules, but alarms are logged for each occurrence. If the modules temperature falls to 5° lower than the warning threshold temperature, the system clears the alarm and an SNMP trap.

Table B-1. Alarm Events and Reporting

Module	Alarm Event	Alarm LED	Reported in event log	Status LED on Module
Fan	Entire Fan Tray fails	major (red)	major	unlit
	1 or 2 individual fans fail	minor (amber)	minor	unlit
Power Supply	Power Supply input power fail	major (red)	major	unlit
	Power Supply power fails at boot ^a	unlit	not reported	unlit
Fan tray	More than one fan within the module fails or hardware failure in the module	major (red)	major	amber
	One fan within the module fails	minor (amber)	minor	amber

Table B-1. Alarm Events and Reporting

Module	Alarm Event	Alarm LED	Reported in event log	Status LED on Module
AC Power Supplies	Hardware failure in a non-redundant power configuration (3 power supplies)	major (red)	major	red or unlit
	Hardware failure in a redundant power configuration (4 power supplies)	minor (amber)	minor	red or unlit
Line Card	Hardware failure	major (red)	major	amber
	Exceeds high temperature limit	major (red)	major	unlit
	Exceeds warning temperature limit	minor (amber)	minor	green
	Individual interface fails	minor (amber)	reported	amber ^b
RPM (Non-redundant Configuration with 1 RPM)				
	Exceeds high temperature limit	major (red)	major	unlit
	Exceeds warning temperature limit	minor (amber)	minor	green
	RPM fails but CP is ok	major (red)	major	amber
SFM3s (Redundant Configuration with 9 or 10 SFM3s)				
	Exceeds high temperature limit	major (red)	major	unlit
	Exceeds warning temperature limit	minor (amber)	minor	green
	Any card fails	minor (amber)	minor	amber
	Any card removed	minor (amber)	minor	unlit
8 SFM3s (Non-Redundant Configuration)				
	Exceeds high temperature limit	major (red)	major	unlit
	Exceeds warning temperature limit	minor (amber)	minor	green
	Any card fails	major (red)	major	amber
	Any card removed	major (red)	major	unlit

a. Event appears only in the show alarms command output.

b. The interface's Link LED is unlit.

Power Supplies Alarms

If a Power Supply fails while the E1200i is operating, the software generates a major alarm and an SNMP trap, and lights the major LED.

When a Power Supply fails, the software also records one alarm event for line cards, RPM, and SFM3, though each contains its own power source. The system generates one alarm event and SNMP trap summarizing the Power Supply failure and the components affected.

AC Power Supplies and Alarms

During system boot, if the redundant power supply (the fourth power supply) is missing or fails, the FTOS does not generate any alarm messages since the minimum configuration of three power supplies is operating. Yet, if a fourth AC power supply is installed, and later one of the four power supplies is removed or fails, the system generates a minor alarm.

If only three power supplies are installed and one of them fails while the E1200 is operating, the software generates a major alarm and an SNMP trap, lights the major LED, and activates the audible alarm.

When you operate the E1200 with three AC power supplies and six or more line cards, the software lists a redundancy alarm on the console and in the show alarms command output. All line cards operate normally.

SFM3s and Alarms

The number of SFM3s present in the system when it boots determines the level of alarms sent when a redundant SFM3 is removed or fails. At boot time, if 9 or 10 SFM3s are present and functioning, the E1200 system issues no alarms. However, if one SFM3 fails or is removed, the system sends a minor alarm. The system requires eight functioning SFM3s to pass traffic.

At boot time, if eight SFM3s are present and functioning, the E1200 system issues no alarms. The system issues no alarms if an SFM3 is added to the system; however, if the number of functioning SFM3s changes from nine to eight, the system sends a minor alarm event. The system always triggers a major alarm when the number of working SFM3s reaches seven.

System Specifications

This appendix contains two major sections:

- [E1200i AC Chassis Physical Design](#)
- [E1200i AC System Power Requirements](#)
- [E1200i DC Chassis Physical Design](#)
- [E1200i DC System Power Requirements](#)
- [Environmental Specifications](#)
- [Agency Compliance](#)

E1200i AC Chassis Physical Design

Parameter	Specifications
Height	42 inches (106.68 cm)
Width	17.40 inches (44.20 cm)
Depth (without cable management system)	22.25 inches (56.51 cm)
Chassis weight with factory-installed components (backplane and air filter)	139 pounds (approx.) (63.05kg)
Weight fully loaded (backplane, air filter, 2 fan trays, 10 SFM3s, RPMs, and 14 line cards)	422 pounds (approx.) (191.2 kg)
Mounting	Attached rack mount brackets are factory set for front mounting in a standard 19-inch rack. Mounting brackets are adjustable for center and rear mounting. Optional brackets are available for front or center mounting in a 23-inch rack or cabinet.
Rack clearance required	Front: 18 inches Rear: 20 inches
Thermal Output	
Maximum (fully-loaded chassis with 10-port 10GE line cards)	18,368 BTU/hr
Minimum (chassis with one 10-port 10GE line card)	2,313 BTU/hr

E1200i AC System Power Requirements

Parameter	Specifications
Nominal Input Voltage	200-240 VAC 50/60 Hz
Maximum Power Consumption	6,634 Watts
Maximum Thermal Output (5,700 W)	19,449 BTU/hour
Maximum Input Current (per power supply)	15.0 A @ 200 VAC 12.5 A @ 240 VAC
Maximum System Power Input	6.0 KVA @ 200/240 VAC

E1200i DC Chassis Physical Design

Parameter	Specifications
Height	36.75 inches (93.35 cm)
Width	17.40 inches (44.20 cm)
Depth (without cable management system)	21.25 inches (53.98 cm)
Chassis weight with factory-installed components (backplane and air filter)	97 pounds (approx.) (44.00 kg)
Weight fully loaded (backplane, air filter, 2 fan trays, 10 SFM3s, RPMs, and 14 line cards)	319 pounds (approx.) (144.70 kg)
Mounting	Attached rack mount brackets are factory set for front mounting in a standard 19-inch rack. Mounting brackets are adjustable for center and rear mounting. Optional brackets are available for front or center mounting in a 23-inch rack or cabinet.
Rack clearance required	Front: 18 inches Rear: 20 inches
Thermal Output	
Maximum (fully-loaded chassis with 10-port 10GE line cards)	16,446 BTU/hr
Minimum (chassis with one 10-port 10GE line card)	1,997 BTU/hr

E1200i DC System Power Requirements

Parameter	Specifications
Nominal Input Voltage	-44 to -60 VDC
Maximum Power Consumption	5,400 W
Maximum Thermal Output (5,100 W)	17,402 BTU/hour
Maximum Input Current (per DC PEM)	150 A

Environmental Specifications

Operating	Specifications
Temperature	32° to 104°F (0° to 40°C)
Maximum altitude	No performance degradation to 10,000 feet (3,048 meters)
Relative humidity	5 to 85 percent, noncondensing
Shock	Designed to meet Telcordia GR-63 CORE
Vibration	Designed to meet Telcordia GR-63 CORE
Non-operating	
Temperature	-40° to 158°F (-40° to 70°C)
Maximum altitude	15,000 feet (4,572 meters)
Relative humidity	5 to 95 percent, noncondensing
Vibration	Bellcore GR-63

Agency Compliance

The E1200 is designed to comply with the following safety and agency requirements.

USA Federal Communications Commission (FCC) Statement

This equipment has been tested and found to comply with the limits for a Class A digital device, pursuant to Part 15 of the FCC rules. These limits are designated to provide reasonable protection against harmful interference when the equipment is operated in a commercial environment. This equipment generates, uses, and can radiate radio frequency energy. If it is not installed and used in accordance to the instructions, it may cause harmful interference to radio communications. Operation of this equipment in a residential area is likely to cause harmful interference, in which case users will be required to take whatever measures necessary to correct the interference at their own expense.

Properly shielded and grounded cables and connectors must be used in order to meet FCC emission limits. Dell Force10 is not responsible for any radio or television interference caused by using other than recommended cables and connectors or by unauthorized changes or modifications in the equipment. Unauthorized changes or modification could void the user's authority to operate the equipment.

This device complies with Part 15 of the FCC Rules. Operation is subject to the following two conditions: (1) this device may not cause harmful interference, and (2) this device must accept any interference received, including interference that may cause undesired operation.

Canadian Department of Communication Statement

Industry Canada Class A emission compliance statement

This Class A digital apparatus complies with Canadian ICES-003.

Avis de conformité à la réglementation d'Industrie Canada

Cet appareil numérique de la classe A est conforme à la norme NMB-003 du Canada.

European Union EMC Directive Conformance Statement

This product is in conformity with the protection requirements of EU Council Directive 2004/108/EC on the approximation of the laws of the Member States relating to electromagnetic compatibility. Dell Force10 cannot accept responsibility for any failure to satisfy the protection requirements resulting from a non-recommended modification of this product, including the fitting of non-Dell Force10 option cards.

This product has been tested and found to comply with the limits for Class A Information Technology Equipment according to CISPR 22/ European Standard EN 55022. The limits for Class A equipment were derived for commercial and industrial environments to provide reasonable protection against interference with licensed communication equipment.

 **WARNING:** This is a Class A product. In a domestic environment, this device may cause radio interference, in which case, the user may be required to take adequate measures.

European Community Contact

Dell Force10, EMEA - Central
 Dahlienweg 19
 66265 Heusweiler
 Germany
<http://www.force10networks.com/german/>
 Tel: +49 172 6802630
 Email: EMEA Central Sales

Japan: VCCI Compliance for Class A Equipment

この装置は、情報処理装置等電波障害自主規制協議会（VCCI）の基準に基づくクラスA情報技術装置です。この装置を家庭環境で使用すると電波妨害を引き起こすことがあります。この場合には使用者が適切な対策を講ずるよう要求されることがあります。

This is Class A product based on the standard of the Voluntary Control Council For Interference by Information Technology Equipment (VCCI). If this equipment is used in a domestic environment, radio disturbance may arise. When such trouble occurs, the user may be required to take corrective actions.

⚠ WARNING: AC Power cords are for use with Dell Force10 equipment only. Do not use Dell Force10 AC power cords with any unauthorized hardware.

本製品に同梱いたしております電源コードセットは、本製品専用です。本電源コードセットは、本製品以外の製品ならびに他の用途で使用することは出来ません。製品本体には同梱された電源コードのみを使用してください。

Korea (MIC certification)

Korean Class A Warning Statement

이 기기는 업무용으로 전자파 적합등록을 받은 기기 이오니, 판매자 또는 사용자는 이점을 주의하시기 바라며, 만약 잘못 구입하셨을 때에는 구입한 곳에서 비업무용으로 교환하시기 바랍니다.

Korea Certification

A급 기기
 (업무용 방송통신기자재)

이 기기는 업무용(A급) 전자파적합기기로서 판매자 또는 사용자는 이 점을 주의하시기 바라며, 가정외의 지역에서 사용하는 것을 목적으로 합니다.

Korea Information

	 [equipment type]
품명(Product Name)	Ethernet Switch
모델명(Model)	[model number]
신청인(Applicant)	Force10 Networks, Inc.
제조사(Manufacturer)	Delta Networks, (Dongguan) Ltd.
제조년월(Manufacturing Date)	[date]
제조국(Country of Origin)	China

Safety Standards and Compliance Agency Certifications

- CUS UL 60950-1, 1st Edition
- CSA 60950-1-03, 1st Edition
- EN 60950-1, 1st Edition
- EN 60825-1 Safety of Laser Products—Part 1: Equipment Classification Requirements and User's Guide
- EN 60825-2 Safety of Laser Products—Part 2: Safety of Optical Fibre Communication Systems
- FDA Regulation 21CFR 1040.10 and 1040.11
- IEC 60950-1, 1st Ed., including all National Deviations and Group Differences

Electromagnetic Emissions

- USA: FCC CFR47 Part 15, Subpart B, Class A
- Canada: ICES-003, Issue-4, Class A
- Europe: EN 55022 2006 (CISPR 22: 2007), Class A
- Japan: VCCI V3/2007.04 Class A
- Australia/ New Zealand: AS/NZS CISPR 22: 2006, Class A

Immunity

- EN61000-3-2 Harmonic Current Emissions
- EN6100-3-3 Fluctuation and Flicker
- EN 61000-4-2 ESD
- EN 61000-4-3 Radiated Immunity
- EN 61000-4-4 EFT
- EN 61000-4-5 Surge
- EN 61000-4-6 Low Frequency Conducted Immunity

- EN 300 386 V1.3.3 (2005) EMC for Network Equipment
- EN 55024 1998 +A1:2001 +A2:2003

Product Recycling and Disposal

This switch must be recycled or discarded according to applicable local and national regulations. Dell Force10 encourages owners of information technology (IT) equipment to responsibly recycle their equipment when it is no longer needed. Dell Force10 offers a variety of product return programs and services in several countries to assist equipment owners in recycling their IT products.

Waste Electrical and Electronic Equipment (WEEE) Directive for Recovery, Recycle and Reuse of IT and Telecommunications Products

Dell Force10 switches are labeled in accordance with European Directive 2002/96/EC concerning waste electrical and electronic equipment (WEEE). The Directive determines the framework for the return and recycling of used appliances as applicable throughout the European Union. This label, as shown in [Figure C-1](#), is applied to various products to indicate that the product is not to be thrown away, but rather reclaimed upon end of life per this Directive.

Figure C-1. The European WEEE symbol



In accordance with the European WEEE Directive, electrical and electronic equipment (EEE) is to be collected separately and to be reused, recycled, or recovered at end of life. Users of EEE with the WEEE marking per Annex IV of the WEEE Directive, as shown above, must not dispose of end of life EEE as unsorted municipal waste, but use the collection framework available to customers for the return, recycling and recovery of WEEE. Customer participation is important to minimize any potential effects of EEE on the environment and human health due to the potential presence of hazardous substances in EEE.

Dell Force10 products, which fall within the scope of the WEEE, are labeled with the crossed-out wheeled-bin symbol, as shown above, as required by WEEE.

For information on Dell Force10 product recycling offerings, see the WEEE Recycling instructions on iSupport at: <https://www.force10networks.com/CSPortal20/Support/WEEEandRecycling.pdf>.

For more information, contact the Dell Force10 Technical Assistance Center (TAC) (see [Appendix ,](#)).

For California:

Perchlorate Material — Special handling may apply.

See: <http://www.dtsc.ca.gov/hazardouswaste/perchlorate>

The foregoing notice is provided in accordance with California Code of Regulations Title 22, Division 4.5 Chapter 33. Best Management Practices for Perchlorate Materials.

Technical Support

This appendix contains these major sections:

- [The iSupport Website](#)
- [Contacting the Technical Assistance Center on page 88](#)
- [Requesting a Hardware Replacement on page 89](#)

The iSupport Website

iSupport provides a range of documents and tools to assist you with effectively using Dell Force10 equipment and mitigating the impact of network outages. Through iSupport you can obtain technical information regarding Dell Force10 products, access to software upgrades and patches, and open and manage your Technical Assistance Center (TAC) cases. Dell Force10 iSupport provides integrated, secure access to these services.

The iSupport website (see [Figure](#) , below) (<http://www.force10networks.com/support/>) contains a publicly available interface that includes access to techtips, white papers, and user manuals. After you get an account and log in, the available documentation expands to other types, including bug lists, error message decoder, release notes. You can even track your own Dell Force10 inventory.

Once you are logged in, the following five tabs become available:

- **Home:** Summary of open cases, RMA management, and field notices (as shown below)
- **Service Request:** Case management
- **Software Center:** Software downloads, bug fixes, and bug tracking tool
- **Documents:** User documentation, FAQs, field notices, technical tips, and white papers
- **Support Programs:** Information on the suite of Dell Force10 support and professional support services.

The Support Policies section of iSupport contains the *Support Guide*, which details the types of information and services that you can access through iSupport and through various types of support contracts.

Accessing iSupport Services

The URL for iSupport is <http://www.force10networks.com/support/>. To access iSupport services you must have a userid and password. If you do not have one, you can request one at the website:

- 1 On the Dell Force10 iSupport page, click the **Account Request** link.
- 2 Fill out the User Account Request form, and click **Send**. You will receive your userid and password by E-mail.

- 3 To access iSupport services, click the **LOGIN** link, and enter your userid and password. See [Contacting the Technical Assistance Center](#), below, for more.

Contacting the Technical Assistance Center

How to Contact Dell Force10 TAC	Log in to iSupport at http://www.force10networks.com/support/ , and select the Service Request tab.
Information to Submit When Opening a Support Case	<ul style="list-style-type: none"> • Your name, company name, phone number, and E-mail address • Preferred method of contact • Model number • Serial Number (see Requesting a Hardware Replacement on page 89) • Software version number • Symptom description • Screen shots illustrating the symptom, including any error messages. These can include: <ul style="list-style-type: none"> • Output from the <code>show tech-support [non-paged]</code> command (This report is very long, so the storage buffer in your terminal program should be set high.) • Output from the <code>show logging eventlog [unit]</code> command, where <i>unit</i> is the stack ID of the member unit that experienced the failure (This report is included as a section in the output of <code>show tech-support</code>.) • Console captures showing the error messages • Console captures showing the troubleshooting steps taken • Saved messages to a syslog server, if one is used
Managing Your Case	Log in to iSupport, and select the Service Request tab to view all open cases and RMAs.
Downloading Software Updates	Log in to iSupport, and select the Software Center tab.
Technical Documentation	Log in to iSupport, and select the Documents tab. This page can be accessed without logging in via the Documentation link on the iSupport page.
Contact Information	<p>E-mail: support@force10networks.com</p> <p>Web: http://www.force10networks.com/support/</p> <p>Telephone:</p> <p>US and Canada: 866.965.5800</p> <p>International: 408.965.5800</p>

Requesting a Hardware Replacement

To request replacement hardware, follow these steps:

Step	Task
1	Determine the part number and serial number of the component. To list the numbers for all components installed in the chassis, use the <code>show hardware</code> command.
2	Request a Return Materials Authorization (RMA) number from TAC by opening a support case. Open a support case by: <ul style="list-style-type: none">• Using the Create Service Request form on the iSupport page (see Contacting the Technical Assistance Center on page 88).• Contacting Dell Force10 directly by E-mail or by phone (see Contacting the Technical Assistance Center on page 88). Provide the following information when using E-mail or phone:<ul style="list-style-type: none">• Part number, description, and serial number of the component.• Your name, organization name, telephone number, fax number, and e-mail address.• Shipping address for the replacement component, including a contact name, phone number, and e-mail address.• A description of the failure, including log messages. This generally includes:<ul style="list-style-type: none">• Output from the <code>show tech-support [non-paged]</code> command (This report is very long, so the storage buffer in your terminal program should be set high.)• Output from the <code>show logging eventlog [unit]</code> command, where <i>unit</i> is the stack ID of the member unit that experienced the failure (This report is included as a section in the output of <code>show tech-support</code>.)• Console captures showing the error messages• Console captures showing the troubleshooting steps taken• Saved messages to a syslog server, if one is used

Index

A

- AC Power Supply
 - minimum requirement 29
- air filter
 - replacing 65
- air flow 16, 17
- alarms
 - fan trays 59
 - line cards 63
 - Power Supplies 60, 61
 - RPMs 63
 - SFMs 63

B

- blanks 45

C

- cable management system 49
- commands
 - show logging eventlog 89
 - show tech 89
- connecting
 - auxiliary port 51
 - console port 51
 - line card ports 49
 - management port 54
- contacting TAC (technical support) 87

D

- Danger 7
- DC PEMs
 - cable requirements 36
 - connector requirements 36
 - full redundancy 35
 - minimum requirement 35
 - remote power source 35
- disposal, switch 86

E

- ESD 43, 63
- European WEEE Directive 86
- external flash

- copying files 69
- formatting 68
- inserting 67
- installing 68
- overview 67
- removing 68
- when to insert external flash 67

F

- fan trays
 - installing 28
 - replacing 59

H

- hardware, requesting replacement 89
- High Touch Current
 - see Leakage Current 8, 31, 55

I

- installing
 - chassis
 - in equipment cabinet 22, 26
 - in rack 20, 24
 - fan trays 28
 - line cards 43
 - PEMs 37
 - rack shelf 20, 24
 - RPMs 43
 - SFMs 48
- iSupport 87

L

- Leakage Current 8, 31, 32, 55
- LEDs
 - AC power supplies 32, 41
 - fans 32, 41, 56
 - In Use LED 68
 - line card 48
 - PEM Voltage LED 40
 - Power Supply 56
 - Power Supply Status 32, 41
 - SFMs 49

M

modem
connecting to the system 54

N

numbering
line card ports 44
line card slots 44
RPM slots 44

P

PEMs
installing 37
PEMs, Installing 36
pin assignments
auxiliary port 54
console port 52
DB-9 adapter 53
power
turning off 56
turning on 56
power requirements 29, 35
Power Supply
DC Cables 36
replacing 60, 61
Power Supply and Fan Operability Test 31, 40

R

rack
installing 21, 25
mounting 16
placement 16
recycling, switch 86
removing
air filters 65
fan trays 59
line cards 63
Power Supply 62
RPMs 63
SFM 63, 64
requesting replacement hardware 89
requirements, AC power 29
Route Processor Module (RPM) 9
RPM (Route Processor Module) 9

S

safety considerations
cabinet placement 16
equipment site selection 15
rack mounting 16
SFM (Switch Fabric Module) 9
show logging eventlog command 89
show tech command 89
specifications
chassis 81, 82
environmental 15
storing components 17
support contacts 87
Switch Fabric Module (SFM) 9
switch recycling 86
system boot
BOOT_USER 71, 72
break control sequence 71
commands
? (question mark) 72
boot change 74
default-gateway 75
dir flash 76
dir slot0 76
help 72
interface management ethernet ip address 75
interface management port config 100m 75
interface management port config 10m 75
interface management port config auto-negotiate 75
interface management port config full-duplex 75
interface management port config half-duplex 75
interface management port config no auto-negotiate 75
interface management port config show 75
reload 76
show boot selector 72
show bootflash 73
show bootvar 73
show default-gateway 75
show interface management ethernet 75

T

Technical Assistance Center (TAC), contacting 87

Test, Power Supply and Fan Operability 31, 40

U

unpacking 19, 23

W

Warning 7

WEEE 86



Printed in the U.S.A.

www.dell.com | support.dell.com